

---

**VOLUME 11 ENVIRONMENTAL  
ASSESSMENT  
SECTION 3 ENVIRONMENTAL  
ASSESSMENT  
TECHNIQUES**

---

**PART 1**

**HA 207/07**

**AIR QUALITY**

**SUMMARY**

This Advice Note gives guidance on the assessment of the impact that road projects may have on local regional air quality. It includes a calculation method to estimate local pollutant concentrations and regional emissions for air including those for carbon. Where appropriate, this advice may be applied to existing roads.

**INSTRUCTIONS FOR USE**

1. Remove Contents pages from Volume 11 and insert new Contents pages dated May 2007.
2. Remove the document entitled 'Air Quality' dated February 2003 from Volume 11, Section 3, Part 1 which is superseded by HA 207/07 and archive as appropriate.
3. Insert the new Advice Note HA 207/07 into Volume 11, Section 3.
4. Please archive this sheet as appropriate.

Note: A quarterly index with a full set of Volume Contents Pages is available separately from The Stationery Office Ltd.



**THE HIGHWAYS AGENCY**



**TRANSPORT  
SCOTLAND**

**TRANSPORT SCOTLAND**



**Llywodraeth Cynulliad Cymru  
Welsh Assembly Government**

**WELSH ASSEMBLY GOVERNMENT  
LLYWODRAETH CYNULLIAD CYMRU**



**Department for  
Regional Development  
www.drni.gov.uk**

**THE DEPARTMENT FOR REGIONAL DEVELOPMENT  
NORTHERN IRELAND**

# **Air Quality**

**Summary:** This Advice Note gives guidance on the assessment of the impact that road projects may have on local regional air quality. It includes a calculation method to estimate local pollutant concentrations and regional emissions for air including those for carbon. Where appropriate, this advice may be applied to existing roads.

**REGISTRATION OF AMENDMENTS**

| Amend No | Page No | Signature & Date of incorporation of amendments | Amend No | Page No | Signature & Date of incorporation of amendments |
|----------|---------|---|----------|---------|---|
|          |         |   |          |         |   |

**REGISTRATION OF AMENDMENTS**

| Amend No | Page No | Signature & Date of incorporation of amendments | Amend No | Page No | Signature & Date of incorporation of amendments |
|----------|---------|---|----------|---------|---|
|          |         |   |          |         |   |

---

**VOLUME 11 ENVIRONMENTAL  
ASSESSMENT  
SECTION 3 ENVIRONMENTAL  
ASSESSMENT  
TECHNIQUES**

---

**PART 1**

**HA 207/07**

**AIR QUALITY**

**Contents**

Chapter

1. Introduction
2. Air Quality Management in the UK
3. Procedure for Assessing Impacts
4. Enquiries

Annex A Vehicle-Derived Pollutants

Annex B Vehicle Emissions

Annex C Development of the Screening Method

Annex D Using the Screening Method

Annex E Detailed Modelling

Annex F Assessment of Designated Sites

# 1. INTRODUCTION

1.1 This Advice Note gives guidance on the assessment of the impacts that road projects may have on the air environment. This includes local air quality and emissions of pollutants including carbon dioxide (CO<sub>2</sub>). Road transport sources account for a large proportion of the emissions of several air pollutants, although most of the pollutants emitted by road vehicles are also produced by a wide range of industrial, commercial and domestic processes. The vehicle-derived pollutants of concern, and the environmental effects to which they contribute, are summarised in Annex A. The pollutants of most concern near roads are nitrogen dioxide (NO<sub>2</sub>) and particles (PM<sub>10</sub>) in relation to human health and oxides of nitrogen (NO<sub>x</sub>) in relation to vegetation and ecosystems.

1.2 Clean air is an essential ingredient for a good quality of life. The Government is committed to meeting health based air quality criteria for human health and for the protection of vegetation and ecosystems. In addition, the Government and EU Member States must reduce their national emissions of a range of pollutants as these can travel considerable distances and affect air quality across international boundaries. The Government also has targets to reduce emissions of greenhouse gases as these are linked with climate change.

1.3 Each year various projects are undertaken by the Highways Agency (HA), Transport Scotland, Welsh Assembly Government Transport Wales and Department of the Environment for Northern Ireland (referred to hereafter as the 'Overseeing Organisations'). These include major schemes, smaller improvements, technology improvements and maintenance projects. All these different classes of project may change the characteristics of the traffic in a locality, with corresponding impacts on pollutant emissions and air quality. These projects can have positive or negative effects on local air quality or, as is more often the case, beneficial effects in one area and adverse effects in another, depending on where traffic conditions change.

1.4 Every project entering the programme of an Overseeing Organisation requires some form of environmental assessment. The impacts of road projects on air quality are assessed in terms of their effects upon local air quality and change in total emissions across the highway network. An appropriate level of

assessment should be undertaken to reflect the potential for a project to cause adverse environmental consequences. Not all projects will be subject to the same level of assessment in order to meet the requirements of the relevant legislation or guidance. For projects that are likely to have an adverse effect on air quality in a sensitive area, a detailed assessment is likely to be required early on in the assessment process so that the results can feed into the scheme design. Any modifications required can then be incorporated at an early stage thus minimising delays to the project. Reference should be made to DMRB 11.2.1 and 11.2.2 when carrying out an air quality assessment as these document the principles of environmental assessment.

## 2. AIR QUALITY MANAGEMENT IN THE UK

2.1 This section provides a summary of the relevant legislation that forms the basis for the assessment of impacts on air quality and the legislation in place to reduce emissions.

### Local Air Quality

2.2 In 1996, the Council of the European Union adopted Framework Directive 96/62/EC on ambient air quality assessment and management, called the Air Quality Framework Directive<sup>1</sup>. This Directive covers the revision of previously existing legislation and introduces new air quality criteria for previously unregulated air pollutants. It sets the strategic framework for tackling air quality consistently by setting European-wide, legally binding limit values for twelve air pollutants in a series of daughter directives<sup>2</sup>. The first three Daughter Directives have been translated into UK law through the Air Quality Limit Value Regulations 2003 or equivalent regulations in the Devolved Administrations and the fourth Daughter Directive will be transposed into UK legislation in 2007 (see Annex A).

2.3 The Framework Directive, as well as its Daughter Directives, requires the assessment of the ambient air quality existing in Member States on the basis of common methods and criteria. Member States are required to report to the Commission each year whether or not the limit values set in the Directive have been achieved. The Department of the Environment, Food and Rural Affairs (Defra) and the Devolved Administrations are the “Competent Authorities” for air quality in the UK, with statutory powers and duties for managing air quality.

2.4 In 2001 the Commission launched “Clean Air for Europe” (CAFE), a programme of technical analysis and policy development, under the Sixth Environmental Action Programme (6EAP). The aim of CAFE was to

develop a long-term, strategic and integrated policy advice to protect against significant negative effects of air pollution on human health and the environment. A new phase of CAFE – the implementation of the Thematic Strategy on Air Pollution – started in September 2005. The Thematic Strategy sets specific interim objectives for reducing air pollution impacts by 2020, in particular for fine particles. EU Member States are currently negotiating a proposed Air Quality Directive. The European Parliament’s Environment Committee had adopted a formal recommendation in June 2006. The Council’s ‘common position’ could be published later in 2006 and the directive is likely to be adopted in summer 2007 and come into effect in 2008.

2.5 In the UK, the introduction of the Environmental Protection Act 1990 and the Environment Act 1995 marked the biggest steps forward in controlling air pollution since the Clean Air Acts of the 1950s and 1960s. Part 1 of the 1990 Act provided regulators with powers to set emission limits and environmental quality standards for individual pollutants; and make plans setting limits on total amounts of pollutants that could be emitted. The 1995 Act required the UK Government and the Devolved Administrations to produce a national air quality strategy containing standards and objectives for improving ambient air quality.

2.6 The current Air Quality Strategy for England, Scotland, Wales and Northern Ireland<sup>3</sup> was published in January 2000 with an addendum<sup>4</sup> released in February 2003. A revision to the Strategy is expected in 2007. The Strategy establishes the framework for achieving further improvements in ambient air quality in the UK and identifies actions at local, national and international level to improve air quality. It sets health-based standards and objectives for nine pollutants to be achieved between 2003 and 2010. These standards define the level of pollution below which health effects are unlikely to be experienced even by the most sensitive members of the population. These are mainly

<sup>1</sup> Available at <http://ec.europa.eu/environment/air/ambient.htm>

<sup>2</sup> The HA made a commitment in its 2006-7 Business Plan that it would not progress with a major scheme that would worsen the situation overall with regards to compliance with the EU air quality limit values. The Business Plan is available at <http://www.highways.gov.uk> – search for “Business plan”.

<sup>3</sup> The Air Quality Strategy for England, Scotland, Wales and Northern Ireland – Working Together for Clean Air, January 2000 (Cm 4548, SE2000/3, NIA 7).

<sup>4</sup> The Air Quality Strategy for England, Scotland, Wales and Northern Ireland: Addendum, February 2003.

based upon recommendations of the Expert Panel on Air Quality Standards (EPAQS). The objectives are targets for air pollution levels which take account of the costs and benefits of achieving the standard. The Strategy also sets objectives for oxides of nitrogen and sulphur dioxide for the protection of vegetation and ecosystems. The Strategy's objectives are largely the same as EU limit values but in some cases are tighter than the EU legislation.

2.7 There is a significant difference between the status of the EU limit values and the UK Air Quality Strategy objectives. As a member of the European Union, the UK Government is obliged to achieve the requirements of European air quality directives and their legally binding limit values. However, the air quality objectives in the Air Quality Strategy are a statement of policy intentions or policy targets set by the UK Government and the Devolved Administrations. As such, there is no legal requirement to meet the Air Quality Strategy objectives except in as far as these mirror any equivalent legally binding limit in EU legislation. The Strategy's objectives are implemented through the Air Quality Regulations and are given in Annex A.

2.8 Part IV of the Environment Act 1995 requires local authorities to review and assess the current and likely future air quality within their area, against objectives for seven of the main air pollutants. These reviews are known as the "review and assessment" process and are described in Defra's Policy Guidance on Local Air Quality Management (LAQM)<sup>5</sup>. This information is reported back to Defra and the Devolved Administrations, to help them meet their duties under the EU Framework Directive.

2.9 Where any of the prescribed objectives are unlikely to be achieved by the required date within any part of a local authority's area, the authority concerned is required to designate an Air Quality Management Area (AQMA). The AQMA must include the area expected to exceed the objective(s) but the boundaries can be much larger than this. AQMAs range in size from one property to an entire borough. Care should therefore be taken when assessing the impact of a

scheme as the area actually exceeding the Air Quality Strategy objective is often smaller than the AQMA.

2.10 The Strategy objectives apply at locations which are situated outside buildings or other natural or man-made structures above or below ground level and where members of the public are regularly present and might reasonably be expected to be exposed over the relevant averaging period. To aim to achieve the objectives at locations where the highest measurable concentrations occur without regard to whether or not the public might be exposed would be inappropriate and highly inefficient. For example, for a long term (annual mean) objective, an exceedence would be relevant at a property façade but not at a kerbside site; while for a short term (hourly mean) objective, exceedences on the pavement might be relevant for a high street. Relevant locations for each air quality objective are defined in Defra's Technical Guidance on LAQM<sup>6</sup>.

2.11 There are around 470 local authorities in the UK, of which about 200 have declared AQMAs for one or more pollutants. In England, the vast majority have been declared for nitrogen dioxide with a third also declaring for PM<sub>10</sub>. A small number have declared for sulphur dioxide or benzene. The situation is similar in Scotland and Wales although the number of local authorities that have declared AQMAs is considerably lower with less than ten in each. In Northern Ireland, in contrast to England, Scotland and Wales, the majority of AQMAs have been declared for PM<sub>10</sub> with a few also declaring for nitrogen dioxide, with a similar number of declarations as Scotland and Wales. The latest information on which local authorities have declared AQMAs is available from the National Air Quality Archive<sup>7</sup>.

2.12 An Air Quality Action Plan<sup>8</sup> (AQAP) covering the designated area must be prepared by local authorities in response to the declaration of an AQMA. The AQAP sets out which actions have been considered and which will be implemented in pursuit of the achievement of the prescribed objectives. It is prepared in conjunction with the stakeholders, including the highways authorities. For England, guidance is available on the role of the Highways Agency (HA) in local air quality management<sup>9</sup>.

<sup>5</sup> Part IV of the Environment Act 1995 – Local Air Quality Management: Policy Guidance LAQM.PG(03). Defra, 2003.

<sup>6</sup> Part IV of the Environment Act 1995 – Local Air Quality Management: Technical Guidance LAQM.TG(03). Defra, 2003.

<sup>7</sup> <http://www.airquality.co.uk/archive/laqm/laqm.php>

<sup>8</sup> Under the Government's freedoms and flexibilities' agenda, those local authorities classed as excellent are no longer required to produce an air quality action plan; however, they still have to take action to work towards meeting the air quality objectives. These freedoms and flexibilities will shortly be extended to those authorities classed as 4\*.

<sup>9</sup> Highways Agency – The Role of the HA in Local Air Quality Management, available at <http://www.highways.gov.uk>



## Regional Impacts

2.13 Local air quality is characterised by pollutants with short term, immediate impacts, but many of these pollutants can also travel longer distances, and can have impacts on a regional, national, or international scale. These impacts, which include acidification, excess nitrogen deposition and generation of tropospheric (ground level) ozone, may be felt by humans or ecosystems at considerable distances from the source of the emissions.

2.14 The UK Government has international commitments to reduce national emissions of oxides of nitrogen, oxides of sulphur, volatile organic compounds (VOCs), ammonia (NH<sub>3</sub>), heavy metals and persistent organic pollutants through UNECE protocols. The European Union's Auto-Oil programme of research and legislation is very influential in defining emission limits for road transport and is driven by the need to reduce emissions on a European scale. The European Commission National Emission Ceilings Directive (NECD), and the UNECE Gothenburg Protocol, set emission ceilings for the above pollutants. The Gothenburg Protocol also sets emission limit values for certain sources of the pollutants. These agreements are part of a series of complementary international measures addressing transboundary air pollution.

2.15 As a result of the long range nature of the impact of some pollutants, a consideration of the change in emissions resulting from a scheme is therefore useful in the context of regional air pollution. This is called the regional impact assessment.

## Climate Change

2.16 Climate change is increasingly recognised as a serious threat to our environment, as well as the economy. As part of its Climate Change Programme<sup>10</sup>, the UK Government is committed to reducing emissions of the gases responsible for climate change. The UK has a legally-binding target known as the Kyoto Protocol, to cut the emissions of a basket of six greenhouse gases to, on average, 12.5% below 1990 levels, between 2008 and 2012. The Government also has a domestic goal to achieve a 20% reduction in emissions of carbon dioxide, the most important greenhouse gas, below 1990 levels by 2010.

2.17 Carbon dioxide (CO<sub>2</sub>) accounted for about 85% of the UK's man made greenhouse gas emissions in 2004. In this year, the percentage of total emissions accounted for by the transport sector was 28%, to which road transport is by far the biggest contributor (21% of total). Since 1990, road transport emissions of this pollutant have increased by 9%. Two other of the six greenhouse gases of importance to climate change are nitrous oxide (N<sub>2</sub>O) and methane (CH<sub>4</sub>). Nitrous oxide is emitted by road transport as a result of the use of catalytic converters and methane is released from some fuel combustion, albeit in much smaller quantities than carbon dioxide.

2.18 As noted above, carbon dioxide is considered the most important greenhouse gas and, therefore, is used as the key indicator for the purposes of assessing the impacts of projects on climate change. The change in carbon emissions is included in the regional impact assessment.

## Vehicle Emissions

2.19 The introduction of tighter European vehicle emission and fuel quality standards since 1993 has been the most important way of reducing vehicle emissions and improving air quality. Vehicle emission standards are tightened every five years or so resulting in a steady decrease in emissions of oxides of nitrogen, carbon monoxide, hydrocarbons and particles. The legislation, vehicle emission rates and vehicle fleet composition are described in Annex B.

---

<sup>10</sup> Climate Change The UK Programme 2006. HM Government. CM6764. March 2006.

## 3. PROCEDURE FOR ASSESSING IMPACTS

### Introduction

3.1 DMRB 11.1.1 sets out the aims and objectives of environmental assessment. The overall objective is to define the depth of assessment necessary to enable informed decision-making at as early a stage of the project as possible. This necessitates a ‘fit-for-purpose’ assessment method and relies on four ‘Assessment Levels’:

- scoping;
- simple;
- detailed; and
- mitigation/enhancement and monitoring.

3.2 For air quality, each assessment level has two components. The first is for local air quality, that is, estimation of pollutant concentrations that could change as a result of the proposals (nitrogen dioxide, oxides of nitrogen, fine particles (PM<sub>10</sub>), carbon monoxide, benzene and 1,3-butadiene) at specific locations. These concentrations are compared with the air quality criteria set to protect human health or vegetation, as appropriate. Both construction and operational effects should be considered for local air quality. The second component is for the regional impact assessment and examines the change in emissions of a range of pollutants (oxides of nitrogen, particles, carbon monoxide, hydrocarbons and carbon) as a result of operation of the scheme as these can have impacts on the regional, national or international scale. The two components may require different assessment levels. Both components are intended to be consistent with Department of the Environment, Food and Rural Affairs (Defra’s) Technical Guidance on Local Air Quality Management (LAQM) and the National Atmospheric Emissions Inventory<sup>11</sup> (NAEI) and this guidance should be referred to as required. An Excel spreadsheet<sup>12</sup> is

available to carry out the DMRB local and regional air quality calculations at the simple assessment level.

3.3 Throughout the assessment process consideration should be given to the minimisation of any negative impacts of the project on air quality. Information on how this can be achieved is provided in this guidance note under the section on Mitigation/Enhancement and Monitoring. If at any stage of the assessment process, it becomes apparent that there is likely to be a new exceedence or a worsening of an existing exceedence of a mandatory EU limit value, then the Overseeing Organisation must be notified immediately. Mitigation measures should then be developed and discussed with the Overseeing Organisation.

3.4 The results and a summary of the worksheets from the local air quality appraisal prepared for the Appraisal Summary Table using the Transport Appraisal Guidance (as described in web-TAG for England<sup>13</sup>, STAG for Scotland<sup>14</sup> and WelTAG for Wales<sup>15</sup>) gives a very useful indication of the overall change in air quality and should be included in the reports prepared for this environmental assessment. Care should be taken to ensure that an entirely consistent message is being delivered in the air quality environmental assessment and the reporting strands of the TAG appraisal, or where differences become apparent that they are fully explained.

### Assessment Scenarios

3.5 The assessment should be carried out using traffic data for the “Do-Minimum” (without the scheme) and “Do-Something” (with the scheme) scenarios, for the opening year and possibly for a further future year. The worst year in the first 15 years from opening needs to be assessed. The base case should also be assessed.

<sup>11</sup> Available at <http://www.naei.org.uk>

<sup>12</sup> Available at <http://www.highways.gov.uk> – search for “air quality spreadsheet”

<sup>13</sup> Available at <http://www.webtag.org.uk>

<sup>14</sup> Available at <http://www.transportscotland.gov.uk>

<sup>15</sup> Available at <http://new.wales.gov.uk/splash.jsp?orig=/> – available in draft, advice on its application should be sought from the Overseeing Organisation.

3.6 For local air quality, this will be the opening year and possibly a later year if more stringent air quality criteria come into effect at a later date. The earlier years tend to be worst for local air quality as vehicle emissions are set to decrease in the future due to increasingly stringent vehicle emission legislation. Cumulative effects from other projects may also need to be considered as discussed in DMRB 11.2.5 as this could result in a large increase in traffic in a year after the opening year. In addition, the existing year (base case) should also be assessed so that model results can be verified with monitoring data. If construction is expected to last for more than six months, then traffic management measures and the effect of the additional construction vehicles should also be assessed as an additional scenario although this may need to be a qualitative assessment where details of traffic flows are not available.

3.7 For regional impacts, the scenarios for assessment are the opening year and design years, both for the Do-Minimum and Do-Something scenarios and the base case. Carbon emissions are expected to decrease between 2005 and 2020 due to increased vehicle efficiency and the use of biofuels but this will be offset to some extent by traffic growth.

3.8 The air quality assessment should be based on the most likely forecast traffic flows.

### Reporting

3.9 At each reporting stage as discussed in DMRB 11.2.6, a report describing the assessment is needed. This should contain:

- (i) a network diagram indicating roads affected by the proposals, together with information, either on the diagram or in tabular form, for existing year, and future year Do-Minimum and Do-Something traffic flows and speeds;
- (ii) a constraints map for local air quality showing:
  - which roads will be affected by the proposals;
  - the 200 m boundary of roads affected by the proposals with properties and Designated Sites shown;
  - boundaries of Air Quality Management Areas (AQMA) and Designated Sites (see para 3.13);

- Air Quality Strategy objectives and limit value exceedence areas without the proposals and a comment on whether these are likely to deteriorate or improve with the scheme and if known, the exceedence areas with the proposals;
- (iii) assessment of any existing air quality monitoring data or monitoring data collected as part of the scheme design;
  - (iv) a description of the methodology used for any modelling and the verification of the approach used;
  - (v) results of any future year modelling and a description of that work;
  - (vi) results of the TAG appraisal for local air quality;
  - (vii) an outline of further work, either modelling or monitoring, to be carried out at the next stage;
  - (viii) identification of potential mitigation for any exceedences and what effect it is likely to have;
  - (ix) for the regional assessment, the total and change in emissions expected with and without the proposals.

### Assessment Level – Scoping

3.10 The principles of scoping are described in detail in DMRB 11.2.4. In summary, scoping seeks to decide which environmental topics are to be examined in environmental impact assessments and environmental assessments and how much effort should be expended – either a simple or detailed assessment. Scoping can be an ongoing activity that is re-activated at key stages in the project planning process as new information or available alternatives are narrowed to a preferred approach to the project.

#### Local Air Quality

3.11 The objective of this scoping exercise for local air quality is to indicate whether there are likely to be significant impacts associated with particular broadly-defined routes or corridors, as developed by the design organisation and the Overseeing Organisation. The steps to be taken are as follows:

3.12 Obtain traffic data for the Do-Minimum and Do-Something scenarios for the years to be assessed. Identify which roads are likely to be affected by the

proposals. Affected roads are those that meet any of the following criteria:

- road alignment will change by 5 m or more; or
- daily traffic flows will change by 1,000 AADT or more; or
- Heavy Duty Vehicle (HDV) flows will change by 200 AADT or more; or
- daily average speed will change by 10 km/hr or more; or
- peak hour speed will change by 20 km/hr or more.

3.13 Identify on an appropriate map (typically 1:25,000 or 1:10,000 scale) all existing and planned properties where people might experience a change in local air quality, near the affected roads. Particular attention should be paid to the locations of the young, the elderly and other susceptible populations, such as schools and hospitals. In addition, areas likely to experience higher-than-average pollution concentrations, such as tunnel portals, roundabouts and junctions, should be identified. Also identify any nature conservation sites (Designated Sites) and their characteristics. The Designated Sites that should be considered for this assessment are those for which the designated features are sensitive to air pollutants, either directly or indirectly, and which could be adversely affected by the effect of local air quality on vegetation within the following nature conservation sites: SACs (SCIs or cSACs), SPAs, pSPAs, SSSIs and Ramsar sites. Sites designated for geological purposes need not be assessed. Further information on Designated Sites is given in Annex F. Only properties and Designated Sites within 200 m of roads affected by the project need be considered.

3.14 If none of the roads in the network meet any of the traffic/alignment criteria or there are no properties or relevant Designated Sites near the affected roads, then the impact of the scheme can be considered to be neutral in terms of local air quality and no further work is needed.

3.15 If any roads are affected by the proposals and have relevant properties or Designated Sites nearby, then examine the available monitoring data and LAQM reports for the area likely to be affected by the project. If an AQMA has been declared for the pollutants of interest, the LAQM report should be carefully studied to identify the boundaries of the AQMA, where the

actual Air Quality Strategy objective exceedance area is within the AQMA and whether the EU limit values are likely to be met at relevant properties in the relevant year. Identify areas where it is likely that air quality will improve or deteriorate as a result of changes to traffic flows and traffic speed, or as a result of reduced congestion or queuing times, due to the proposals.

3.16 The judgement of someone with relevant air quality expertise should be used to identify possible locations alongside affected roads and new roads where there may be exceedances of the Air Quality Strategy objectives or limit values. If such locations are identified then undertake a few calculations for the pollutants of concern using the 'Local' application of the DMRB Air Quality Screening Method spreadsheet for the 'worst' affected properties and identify the extent of mitigation required. The instructions for using the spreadsheet are provided in Annex D. The worst affected properties are those that are likely to have the highest pollution concentrations or the largest increases in pollution due to the proposals. The aim of this screening assessment is to quickly identify impacts on a small sample of properties early in the assessment, so that any potential problems are identified. If the proposals are likely to cause a new exceedance of a limit value or a worsening of an expected exceedance, check the calculations and assumptions made and liaise with the Project Team and Overseeing Organisation immediately.

3.17 Determine whether there is sufficient monitoring data already available or whether further monitoring should be undertaken. Measured concentrations, whether from a scheme survey or from existing monitoring, will be needed to verify the model results and to establish a firm baseline. Prepare a brief for further monitoring if needed remembering to include a background monitoring site and to co-locate any passive samplers with a continuous analyser. The extent and complexity of the monitoring will depend upon the size of the project and the risk of exceeding the air quality criteria. Diffusion tubes should be deployed for nitrogen dioxide as a minimum, as these can give a large spatial coverage which will be needed to verify the model results. In complex cases for very major projects and where time permits, a continuous analyser may also be required but this will be rare. Advice on air quality monitoring techniques, monitoring locations, model output verification procedures and application are contained within Defra's Technical Guidance on LAQM.

3.18 If the proposals are expected to alter traffic or road alignment as set out in 3.12 and there are relevant

properties or Designated Sites near the affected roads but no exceedences are identified from the monitoring data, LAQM reports or from the few DMRB screening calculations, then prepare a brief for a simple assessment.

3.19 If the monitoring data or the few DMRB screening calculations indicate that an exceedence of an Air Quality Strategy objective or EU limit value is likely or if the proposals cannot be assessed properly using the DMRB screening method, prepare a brief for the detailed assessment.

### **Regional Impacts**

3.20 For the scoping stage of the regional assessment, identify roads that are likely to be affected by the proposals. Affected roads are those that are expected to have:

- a change of more than 10% in AADT; or
- a change of more than 10% to the number of heavy duty vehicles; or
- a change in daily average speed of more than 20 km/hr.

3.21 If no roads meet these criteria, then it is not necessary to undertake any calculations. However, a qualitative assessment should be made as to whether the project is likely to have a marginal improvement or marginal deterioration in emissions based on the change in distance travelled with the scheme.

3.22 If any roads are likely to be affected by the proposals, then the scoping assessment should recommend that a simple assessment is carried out. An estimate should be made of the change in distance travelled with the scheme in the opening and design years as this will be linked to the change in emissions.

### **Assessment Level – Simple**

3.23 This activity is based on the assembly of data and information beyond that which is readily available. It should enable an understanding to be reached as to the effect of the project or to reach an understanding of the likely effect that identifies the need for a detailed assessment. A simple assessment would be sufficient if it established confidently that the forecast environmental effect would not be a fundamental issue in the decision making process.

3.24 If the scoping assessment indicates that a simple assessment is needed, then the following steps should be followed for local and regional impacts.

### **Local Air Quality**

3.25 Revise as necessary the maps produced during the scoping stage for the various options under consideration, to take account of any project changes and further traffic information. Estimate the number of properties in 50 m bands from the road centre to 200 m from the road centre for each road expected to be affected by the proposals.

3.26 Estimate pollutant concentrations at a wide range of properties that are likely to be affected by the proposals. This should include those that are likely to have the highest concentrations, those that are likely to have the largest changes in concentrations (either decrease or increase), those that are representative of large numbers of properties and those that house the young, the elderly and other susceptible populations. Estimates should be made for a base year and should, where possible, include nearby monitoring locations. The estimates should be made using the 'Local' application of the DMRB Screening Method. The instructions for using the spreadsheet are provided in Annex D.

3.27 Compare the base year model results with measured concentrations and adjust the modelled results as necessary. Care needs to be taken when doing this as it is not straightforward; advice is given in Defra's Technical Guidance on LAQM. The adjusted modelled concentrations should then be compared with the air quality criteria.

3.28 If any of the air quality criteria are estimated to be exceeded with the project in any of the years in which they apply, further calculations should be carried out to determine the first year in which the criteria would be achieved. Furthermore, a detailed assessment will be required.

3.29 If a Designated Site has been identified as likely to be affected by the proposals, NO<sub>x</sub> concentrations and nitrogen deposition rates should be calculated within the site. Further guidance is given in Annex F and in summary involves:

- 1) Calculating annual average NO<sub>x</sub> concentrations in the Designated Site(s) in a transect up to 200 m away from each of the affected roads within or near the Designated Sites. The calculations should be carried out for the opening

year for the Do-Minimum and Do-Something scenarios, and the base year. The DMRB Screening Method should be used to carry out the calculations unless this method is not appropriate for the project being assessed.

- 2) The NO<sub>x</sub> concentrations at the Designated Site(s) should be compared with the vegetation criterion for NO<sub>x</sub> and the change in concentration due to the project determined in the opening year. If the project is expected to cause an increase in concentrations of at least 2 µg/m<sup>3</sup> and the predicted concentrations (including background) are very close to or exceed the criterion, then the sensitivity of that species to NO<sub>x</sub> should be commented upon. Advice from an ecologist or the statutory body should be sought at this stage. The results of this assessment should also be passed to an ecologist for inclusion in the ecological impact assessment (Environmental Statement/environmental report; and or Appropriate Assessment). The ecologist should consider the potential cumulative effects of the various impacts such as air pollution, water pollution and habitat loss and comment upon the effect of the project on the integrity of the Designated Site. If the designated features are at risk of being adversely affected by the project, mitigation measures should be considered to minimise the scale of impact.
- 3) Calculating nitrogen deposition at the location of the Designated Site(s) as described in Annex F and comparing with the critical loads, also given in Annex F.

### **Regional Impacts**

3.31 Calculations should be made of the change in total emissions that will result from the project, as compared with the base and future year 'Do-Minimum' condition. This step should incorporate all affected roads as identified at the scoping level. The 'Regional' application of the DMRB spreadsheet can be used. The traffic models COBA and TUBA can also be used to estimate carbon emissions. However, the TUBA model should be used cautiously as it uses trip average speeds rather than link average speeds. TUBA should not be used in Scotland to estimate carbon emissions from trunk road schemes and further guidance should be sought from Transport Scotland.

### **Assessment Level – Detailed**

3.32 A detailed assessment should be applied where there exists the potential to cause significant effects on environmental resources and receptors. The objective is to gain an in-depth appreciation of the beneficial and adverse consequences of the project and to inform project decisions. A detailed assessment may also be required where the scheme cannot be assessed using simple methods, for instance where there are features that would affect the dispersion of pollution (e.g. tunnels, street canyons) or proposals that would significantly affect peak hour congestion in areas with concentrations estimated to be close to the air quality criteria. Note that it is not always necessary to undertake a detailed modelling assessment for the whole study area but to combine the detailed modelling for complex areas of the scheme with screening methods for the wider affected network.

### **Local Air Quality**

3.33 If the assessment so far has indicated that there is a reasonable risk of EU limit values or Air Quality Strategy objectives being exceeded at relevant locations, or the project includes significant features that cannot be assessed at the simple level, then a detailed level assessment should be carried out by someone with relevant expertise.

3.35 A detailed assessment is expected to take into account all of the parameters that are expected to change as a result of the proposals. It should include representative meteorological data, diurnal variation in flows and speeds and changes to road alignment. If the proposals are likely to result in a change to the way the vehicle is operated without the hourly average speed changing, then advice should be sought from the Overseeing Organisation as to how to assess this.

3.36 The model results must be compared with measured concentrations and adjusted as necessary. Care needs to be taken when doing this as it is not straightforward, advice is given in Defra's Technical Guidance on LAQM. The adjusted modelled concentrations should then be compared with the relevant air quality criteria. Detailed modelling is discussed further in Annex E and in Defra's Technical Guidance.

3.37 An assessment should be made of the significance of the changes in air quality. The assessment should bring together the earlier conclusions about existing and forecast pollution levels in relation to air quality criteria, and the populations and locations

affected. Any change in the extent or severity of exceedences should be carefully noted.

### **Regional Impacts**

3.38 A detailed regional assessment would be one that takes account of diurnal speed changes and changes in emissions from all roads, however small, within the study area. It is unlikely that a detailed assessment would be required for regional emissions as the changes expected will be small in relation to the national emissions and are likely to be adequately assessed at the simple level. The only exception might be where there is a large change in peak hour speeds on a major road due to the proposals, as this cannot be assessed using the DMRB regional impact spreadsheet which uses daily average speeds.

3.39 The COBA traffic model will automatically calculate carbon emissions at a detailed level by taking into account diurnal and seasonal variations across the entire modelled road network.

### **Assessment Level – Mitigation/Enhancement and Monitoring**

3.40 This assessment level involves the iterative design, assessment and identification of measures that could be taken to avoid or reduce adverse impacts or enhance the positive environmental performance of the project, in terms of both health and ecological impacts from construction and operation. Consultations with the Overseeing Organisation will usually be necessary to confirm the appropriateness of extensive and/or atypical mitigation measures. The main design and assessment tasks are to:

- examine the performance of the measure through either predictive techniques or on the basis of experience gained elsewhere; and
- assess whether the measure would give rise to any subsequent environmental consequences not thus far assessed;
- follow up work to monitor or evaluate the effectiveness of the measures to meet the requirements of legislation, guidance or to learn how to do things better in the future.

3.41 The air quality assessment of a road project must include any mitigation measures, as agreed with the Overseeing Organisation's project manager. Consideration must also be given to any impacts on non-strategic roads. A quantification of the likely

benefits resulting from mitigation is required, although for some measures, this may not be possible.

3.42 The scope for mitigating adverse impacts on air quality via route choice, design or operation is limited in comparison with that associated with improved vehicle technology. However, possible mitigation measures might include the following:

### **Route Alignment**

- Increasing the distance between the road and the sensitive location. Realignment by only a few tens of metres may provide significant benefits.
- Orientation of the road relative to locally prevailing winds. If a route can be chosen so that a sensitive location tends to be upwind of the road, average concentrations at that location will be lower than if the sensitive location tends to be downwind.
- Junctions and intersections should be sited to minimise the impact on air quality at sensitive locations. Slow traffic negotiating intersections generally produces greater amounts of pollution than freely flowing traffic.
- Tunnel portals and ventilation shafts should be sited so that the openings do not impact on air quality at sensitive locations. The build-up of pollution in tunnels means that the air expelled from them contains higher concentrations than those observed near open roads. Therefore there is considerable scope for optimising portal design to facilitate improved dispersion and dilution.
- Placing the road in a cutting or on an embankment can increase the distance between a roadside receptor and the vehicles thus allowing more time for dispersion and reducing concentrations at the receptor.

### **Landscape Works**

- The use of vegetation screens or barriers. There is some evidence that concentrations are slightly reduced in a small area on the leeward side (downwind) of a large screen or barrier, but also that pollutant concentrations may actually increase if the wind speed is reduced. Consequently, an understanding of specific effects and their relevance to the local conditions is crucial.

- The use of bunds or screens can divert pollution away from receptors or increase the distance to receptors, thus allowing greater dispersion.

### *Traffic Management*

- Traffic management measures include active traffic management, fixed and variable speed limits, dedicated lanes, hard-shoulder running and ramp metering. Such measures can modify the traffic behaviour so that vehicles operate in a mode that produces lower emissions in free-flow conditions and with less aggressive driving.
- Demand management measures include access control, junction closures, high occupancy vehicle lanes, travel plans and car/bus interchanges at junctions. Such measures can reduce demand for the strategic road network alone or across the wider network.
- Linking the motorway and trunk road signage with those on the local authority receiver/feeder roads to enable better route planning, thus reducing road miles per journey.
- Providing real-time information on severe congestion and road closures so that travellers can avoid these queues and hence adding to emissions.

3.43 Where a route alignment cannot be altered to increase the distance between the road and receptor, speed management may be the most effective measure for a motorway. Enabling vehicles to travel at a steady speed rather than with periods of acceleration is likely to reduce emissions as transient conditions tend to lead to large increases in emissions in modern vehicles. Reducing the speed from 70 mph to 60 mph or 50 mph is also likely to deliver emission reductions but it does depend on the vehicle fleet composition. The effectiveness of a speed change can be assessed by estimating the emissions for each hour of the day for the Do-Something scenario and then with the speed management strategy in place. It is important to undertake the calculations hour by hour as the flows

and speeds will change and in peak hours, speeds may be too low for a reduced speed limit to have any effect. A speed management strategy is likely to be implemented as part of a controlled motorway<sup>16</sup> and could potentially be linked to real-time pollution measurements so that speeds can be reduced when pollution is worst.

3.44 The impact of a road network or project on air quality is just one of the factors to be considered in route choice and design, and conflicts can occur. For example, mitigation measures must also perform to an acceptable level in road safety and economic terms.

### *Construction Dust*

3.45 In addition, dust generated during construction should be mitigated. The locations of any sensitive receptors within 200 m of a construction site should be clearly identified, such as housing, schools, hospitals or designated species or habitats within a Designated Site, so that mitigation measures to reduce dust emissions can be rigorously applied. Examples of good practice for mitigation are given in the Annex 1 of the Minerals Policy Statement<sup>17</sup>. Appropriate measures should reflect the nature of the construction activity (type, dust source points, construction operation periods and calendar dates) as well as ameliorating conditions (such as prevailing wind directions and speeds, typical precipitation and the dampening effect of retained soil moisture). Mitigation measures should be incorporated into the Construction Environmental Management Plan (CEMP), reflecting the requirements of best practicable means (BPM).

---

<sup>16</sup> Controlled motorways are where the mandatory speed limit of 70 mph can be lowered bringing vehicles closer together as their stopping distance is reduced which can keep the traffic flowing at a higher capacity than would otherwise be achieved (albeit at a lower speed) and so reduces flow breakdown.

<sup>17</sup> ODP. Minerals Policy Statement 2: Controlling and mitigating the environmental effects of mineral extraction in England. Annex 1: Dust. Office of the Deputy Prime Minister, London. 2005.



## 4. ENQUIRIES

All technical enquiries or comments on this Advice Note should be sent in writing as appropriate to:

Chief Highway Engineer  
Floor D2  
No 5 Broadway  
Broad Street  
Birmingham  
B15 1BL

S SMITH  
Chief Highway Engineer

Director of Trunk Roads: Infrastructure and  
Professional Services  
Transport Scotland  
Trunk Road Network Management  
8th Floor, Buchanan House  
58 Port Dundas Road  
Glasgow  
G4 0HF

A C McLAUGHLIN  
Director of Trunk Roads: Infrastructure  
and Professional Services

Chief Highway Engineer  
Transport Wales  
Welsh Assembly Government  
Cathays Parks  
Cardiff  
CF10 3NQ

M J A PARKER  
Chief Highway Engineer  
Transport Wales

Director of Engineering  
The Department for Regional Development  
Roads Service  
Clarence Court  
10-18 Adelaide Street  
Belfast BT2 8GB

R J M CAIRNS  
Director of Engineering

## ANNEX A VEHICLE-DERIVED POLLUTANTS

### A1 Pollutants and Environmental Effects

A1.1 In an internal combustion engine, energy is derived from the burning of hydrocarbon fuel in air, with the main products being carbon dioxide (CO<sub>2</sub>) and water vapour (H<sub>2</sub>O). Some of the fuel is either not burnt or only partially burnt, which results in the presence in the exhaust of carbon monoxide (CO), volatile organic compounds (VOCs)<sup>18</sup>, and particulate matter (PM) containing carbon and other substances. In addition, at the high temperatures and pressures found in the combustion chamber, some of the nitrogen in the air and fuel is oxidised, forming mainly nitric oxide (NO) with a small amount of nitrogen dioxide (NO<sub>2</sub>). By convention, the sum total of oxides of nitrogen (i.e. NO + NO<sub>2</sub>) is abbreviated as NO<sub>x</sub>. CO, VOCs, NO<sub>x</sub>, PM and, prior to 2000, lead, have normally been regarded as the pollutants of most concern, and rates of emission are legally restricted in many countries. CO<sub>2</sub>, being a major contributor to global warming, is now also considered to be an atmospheric pollutant. However, some pollutants are known or suspected carcinogens, for which no absolutely safe exposure level can be defined.

A1.2 The compounds released into the atmosphere by road vehicles are involved in a variety of health and environmental effects over different time periods and on different geographical scales. These effects can be immediate and very local – for example, a plume of black smoke arising from a vehicle exhaust pipe can be instantly unpleasant to those people in the vicinity. Over longer time scales, cumulative effects can occur, such as the soiling of buildings and materials repeatedly exposed to vehicle exhaust pollutants. The main direct effects are in the area near to the road, as the rapid dispersion and dilution of pollutants reduces their concentrations significantly. Many of the pollutants emitted from road vehicles react together, and with pollutants from other sources, to form secondary pollutants. Concentrations of secondary pollutants are not always highest near to the primary emission source

because of the time required for their formation. Their impacts may spread over large areas, and are not confined to the locality of the traffic. Vehicle emissions also contribute to a regional degradation of air quality, restricted only by the time taken for their physical removal (e.g. ‘wash out’) or chemical removal (e.g. reaction and transformation) from the air by natural processes. Stable compounds, including greenhouse gases such as CO<sub>2</sub>, may contribute to environmental problems on a global scale for many years.

A1.3 The main vehicle-derived pollutants are described in more detail below. The most significant of these effects are listed in the following paragraphs. However, these are included for guidance and the list is not intended to be exhaustive or comprehensive. There are many hundreds of compounds present in vehicle exhaust, of which only a small fraction have received detailed attention.

A1.4 **Carbon monoxide (CO).** Approximately half of the UK’s emissions of CO were from road transport in 2004<sup>19</sup>. Carbon monoxide is rapidly absorbed by the blood, reducing its oxygen carrying capacity. Because of its effects on human health, it is included in the EU Daughter Directive and UK legislation. It is a relatively stable compound that takes part only slowly in atmospheric chemical reactions. It contributes indirectly to the greenhouse effect by depleting atmospheric levels of hydroxyl radicals, thus slowing the destruction of methane, which is a powerful greenhouse gas.

A1.5 **Oxides of nitrogen (NO<sub>x</sub>).** 37% of the UK’s emissions of NO<sub>x</sub> were from road transport in 2004<sup>19</sup>. The majority of the oxides of nitrogen produced by road vehicles are emitted as NO. Whilst it was originally thought that the proportion of primary NO<sub>2</sub> was of the order of 5% of the total NO<sub>x</sub> in vehicle exhaust, recent studies have indicated that values of up to 20% primary NO<sub>2</sub> may be assumed for diesel vehicles and vehicles with oxidising exhaust after treatment systems. In the atmosphere NO is oxidised to

<sup>18</sup> Several different terms are used to collectively refer to organic compounds in the field of air pollution. The term ‘volatile organic compounds’ is often used. One VOC, methane (CH<sub>4</sub>), is an extremely efficient greenhouse gas, and hence it is common to see a distinction made between methane and non-methane volatile organic compounds (NMVOCs). In the measurement of vehicle emissions there has been a tendency to use the terms hydrocarbons (HC) and non-methane hydrocarbons (NMHC) – these are analogous to VOCs and NMVOCs.

<sup>19</sup> NAEI 2004 Emissions Data Spreadsheet.

NO<sub>2</sub>, which is more toxic and is therefore included in the EU Daughter Directive and the UK legislation. NO<sub>x</sub> also plays a number of important roles in atmospheric chemistry, and contributes to photochemical smog formation and acid deposition. Some of the products of reactions involving NO<sub>x</sub> are powerful greenhouse gases.

**A1.6 Hydrocarbons (HC).** This term generally covers all organic compounds emitted by road vehicles, both in the exhaust and by evaporation from the fuel system, and embraces many hundreds of different species. In the field of air pollution, hydrocarbons are analogous to VOCs. Some hydrocarbon compounds, such as benzene and 1,3-butadiene, are toxic or carcinogenic. Benzene is included in the second EU air quality Daughter Directive and the UK legislation, whereas 1,3-butadiene is included in UK legislation only. Inventories<sup>19</sup> have shown that road transport is a significant source of benzene (23%) and 1,3-butadiene (55%). Hydrocarbons are important precursors of photochemical smog, acidic and oxidising compounds, and they contribute directly and indirectly to the greenhouse effect. However, the reactivity of different hydrocarbon species varies widely. The composition of hydrocarbon emissions is strongly influenced by the composition of the fuel, so changes in fuel specifications can modify their impacts.

**A1.7 Particulate matter (PM).** Road transport was responsible for 23% of the UK's PM<sub>10</sub> emissions in 2004<sup>19</sup>. Particles may be emitted from the exhaust, through the resuspension of road surface dust, and as a result of the abrasion of tyres, brakes and the road surface. Diesel exhaust contains much higher particle mass concentrations than petrol exhaust. Combustion-derived particles generally comprise carbonaceous material, onto which a wide range of organic and inorganic compounds may be adsorbed. Exhaust particles are generally fine, with an aerodynamic diameter of less than 1.0 µm. Secondary particles are also formed through a range of atmospheric chemical processes. Such particles are composed of nitrates and sulphates, which are associated with the acidification of water courses. Studies of the health effects of particles have historically concentrated on their chemical composition, but research has been extended to include effects associated with the particle size and relative surface area. Studies from the United States and elsewhere have shown a correlation between the concentrations of fine particles and mortality and morbidity that seems to be independent of the particulate composition. Particulate matter with an average diameter of less than 10 µm (PM<sub>10</sub>) is included in the EU Daughter Directive and Air Quality Strategy.

In addition, the EU is proposing a PM<sub>2.5</sub> exposure reduction target and PM<sub>2.5</sub> target value which will be followed by a PM<sub>2.5</sub> limit value. An Air Quality Strategy PM<sub>2.5</sub> objective is likely to follow.

**A1.8 Sulphur dioxide (SO<sub>2</sub>).** Road transport represents a negligible source (less than 1%) of UK sulphur dioxide emissions. Concentrations may have been slightly elevated at heavily trafficked roadside locations in the past, but because the maximum permitted sulphur content of road fuels has periodically been reduced, the contribution is now much lower.

**A1.9 Lead (Pb).** Lead is a recognized neurotoxin, and as such is included in both EU and UK legislation. Formerly, lead compounds, mainly in the form of fine particles, were emitted by petrol vehicles using leaded petrol, but the prohibition of leaded petrol from general sale from 2000 has reduced concentrations to levels which are well below those considered harmful, except in a very few locations where there remain industrial or other non-traffic sources of lead pollution.

**A1.10 Carbon dioxide (CO<sub>2</sub>).** Carbon dioxide is a major product of the combustion of all carbon-containing materials, and is the most abundant man-made greenhouse gas in the atmosphere. CO<sub>2</sub> is not considered in local air quality assessment since it is not toxic and causes no adverse environmental effects on a local scale but is included in the regional impact assessments expressed as carbon. Road transport accounted for 21% of the UK's carbon emissions in 2004<sup>19</sup>.

**A1.11 Ozone (O<sub>3</sub>).** Ozone is not produced directly from emission sources, but is created by photochemical reactions in the atmosphere involving oxides of nitrogen, hydrocarbons and other compounds. Because road transport is a major source of the compounds involved in these reactions, it is an important contributor to ground level O<sub>3</sub> concentrations. In the immediate vicinity of roads, the amount of O<sub>3</sub> in the air is governed mainly by the reaction between NO and O<sub>3</sub>, to produce NO<sub>2</sub>. Because roads provide an excess of NO from the traffic emissions, the reaction proceeds until most of the O<sub>3</sub> is depleted, and consequently, O<sub>3</sub> levels near to roads tend to be low. Because the control of O<sub>3</sub> depends ultimately on the control of emissions of NO<sub>x</sub> and HC on a large scale, broad inferences of the effects of a road network or specific project may be based on the regional impact assessment. However, there is increased evidence that O<sub>3</sub> may not have a threshold and may therefore generate greater health impacts than previously expected. Because of the regional generation and destruction of O<sub>3</sub>, objectives

are not prescribed in LAQM regulation. Therefore this objective remains a national objective.

**A1.12 Polycyclic aromatic hydrocarbons (PAHs).** A target value for PAHs was introduced in the fourth EU air quality Daughter Directive. PAHs are produced by all types of combustion, with the most important sources being specific industrial processes such as aluminium production, coke ovens and anode baking. The Air Quality Strategy has recently adopted a PAH standard expressed in terms of an individual marker compound, benzo(a)pyrene (B(a)P), not to exceed 0.25 ng/m<sup>3</sup> as an annual average. Given the relatively low contribution to total PAH from road transport, and the paucity of transport emission data, it is not considered in road assessments. However, whilst the contribution of road transport was approximately half of total UK PAH emissions (based on the sum of the standard 16 species) in 2004, it contributed only 6% of the total B(a)P<sup>19</sup>.

**A1.13 Trace metals.** Target values for cadmium, arsenic, nickel and mercury have been set under the fourth EU air quality Daughter Directive and are likely to be achieved throughout the UK. They are not currently covered by the Air Quality Strategy. Road traffic is a relatively minor source (Cd is 7%, As is 0.01%, Ni is 0.7% and Hg is 0.05%)<sup>19</sup> so these metals are not considered in road assessments.

## A2 Air Quality Criteria

**A2.1** The mandatory air quality criteria operable in the UK are the limit values given in European Union Directives (Table A.1). The Stage 2 PM<sub>10</sub> EU limit values are not going to be pursued by the EU as the Commission has recognised that they are unlikely to generate a cost effective improvement in air quality<sup>20</sup>. The EU target values are not mandatory (i.e are non-legally binding) but represent the maximum concentration in ambient air that a Member State should try to achieve (Table A.1). The UK will be streamlining air quality legislation by consolidating the provisions of the existing Air Quality Limit Value Regulations 2003 with the proposed Air Quality Standards Regulations 2007.

**A2.2** The current Air Quality Strategy sets objectives for nine pollutants to protect human health, seven of which are in Regulations for the purposes of Local Air Quality Management (LAQM). The Strategy objectives are non-mandatory but where the seven regulated objectives are not expected to be met by the target date, a local authority must declare an Air Quality Management Area (AQMA). In addition to the Strategy objectives for the protection of human health, national objectives have been set to protect vegetation and ecosystems, and these are listed in Table A.3.

---

<sup>20</sup> The Air Quality Strategy for England, Scotland, Wales and Northern Ireland- A consultation document on options for further improvements to air quality. Defra, April 2006.

Table A1 Air Quality Criteria in the EU

| Directive  | Limit and Target Values by Pollutant   | Comment  |
|--|--|--|
| 1 <sup>st</sup> Daughter Directive (1999/30/EC)  | <p><b>SO<sub>2</sub></b>: 1-hour limit value 350 µg/m<sup>3</sup>, not to be exceeded more than 24 times per year. 24-hour limit of 125 µg/m<sup>3</sup>, not to be exceeded more than three times per year. Compliance date 01/01/05.</p> <p><b>NO<sub>2</sub></b>: 1-hour limit value 200 µg/m<sup>3</sup>, not to be exceeded more than 18 times per year. Annual limit of 40 µg/m<sup>3</sup>. Compliance date 01/01/10.</p> <p><b>PM<sub>10</sub></b>: (Stage 1) 24-hour mean limit value 50 µg/m<sup>3</sup>, not to be exceeded more than 35 times per year. Annual mean limit of 40 µg/m<sup>3</sup>. Compliance date 01/01/05.</p> <p><b>PM<sub>10</sub></b>: (Stage 2) 24-hr limit value 50 µg/m<sup>3</sup>, not to be exceeded more than seven times per year. Annual limit of 20 µg/m<sup>3</sup>. Compliance date 01/01/10.</p> <p><b>Pb</b>: Annual average limit of 0.5 µg/m<sup>3</sup>. Compliance date 01/01/05 or 2010 in the immediate vicinity of specific industrial locations.</p> | <p>Transposed in England by the Air Quality Limit Values Regulations 2003 SI 2121 and equivalent regulations in the Devolved Administrations.</p> <p>Stage 2 PM<sub>10</sub> limit values are indicative (non-legally binding), are not included in the Regulations and are likely to be removed from the Directive.</p> |
|  | <p><b>NO<sub>x</sub></b>: Annual limit of 30 µg/m<sup>3</sup>. Compliance date 01/01/01.</p> <p><b>SO<sub>2</sub></b>: Annual mean and winter limit (October – March) of 20 µg/m<sup>3</sup>. Compliance date 19/07/01.</p>  | <p>Limit values for vegetation and ecosystems. Transposed in England by the Air Quality Limit Values Regulations 2003 SI 2121 and equivalent regulations in the Devolved Administrations. Targets have been met.</p>   |
| 2 <sup>nd</sup> Daughter Directive (2000/69/EC)  | <p><b>Benzene</b>: Annual average limit value of 5 µg/m<sup>3</sup>. Compliance date 01/01/10.</p> <p><b>CO</b>: Maximum daily running 8-hour mean limit value of 10 mg/m<sup>3</sup>. Compliance date 01/01/05.</p>   | <p>Transposed in England by the Air Quality Limit Values Regulations 2003 SI 2121 and equivalent regulations in the Devolved Administrations.</p>  |
| 3 <sup>rd</sup> Daughter Directive (2002/3/EC)   | <p><b>Ozone</b>:</p> <p>Target Values:</p> <p>Maximum daily 8-hr mean, not to exceed 120 µg/m<sup>3</sup> on more than 25 times per calendar year, averaged over three years. Compliance date 01/01/10.</p> <p>AOT40 (calculated from 1-hr values between May and July not to exceed 18000 µg/m<sup>3</sup>.hr averaged over a five-year period. Compliance date 2010.</p> <p>Long term objectives:</p> <p>Maximum daily 8-hour mean, not to exceed 120 µg/m<sup>3</sup> in a single calendar year. Compliance date 2020.</p> <p>AOT40 (calculated from 1-hr values between May and July not to exceed 6000 µg/m<sup>3</sup>.hr. Compliance date 2020.</p>   | <p>Sets health based target values and long term objectives. Linked with the emissions ceilings directive (2001/81/EC) through interaction as precursors.</p> <p>Transposed in England by the Air Quality Limit Values Regulations 2003 SI 2121 and equivalent regulations in the Devolved Administrations.</p>          |
| 4 <sup>th</sup> Daughter Directive (2004/107/EC)   | <p>Annual targets for arsenic, cadmium, nickel, PAH, for the total content of the PM<sub>10</sub> fraction</p> <p><b>Arsenic</b>: 6 ng/m<sup>3</sup>.</p> <p><b>Cadmium</b>: 5 ng/m<sup>3</sup>.</p> <p><b>Nickel</b>: 20 ng/m<sup>3</sup>.</p> <p><b>PAH</b> (benzo[a]pyrene): 1.0 ng/m<sup>3</sup>.</p> <p>Implementation date 31/12/12.</p>   | <p>Sets health-based target values. As well as the measurement of B(a)P, recommends the measurement of B(a)A, B(a)F, B(j)F, B(f)F, I(1,2,3-cd)P, D(a,h)A and F.</p> <p>Will be incorporated into The Air Quality Standards Regulations 2007.</p>   |
| Thematic strategy on air pollution   | <p><b>PM<sub>2.5</sub></b> annual average limit value of 25 µg/m<sup>3</sup> with an introduction date of 2010.</p>  | <p>Under consultation. This limit may replace the Stage 2 PM<sub>10</sub> limit and an exposure reduction target may be set.</p>   |
| <p>AOT40: the sum of the difference between hourly concentrations greater than 40 ppb and 40 ppb, expressed in µg/m<sup>3</sup>, over a given period using only 1-hr values measured between 08:00 and 20:00.</p> <p>B(a)A, benzo(a)anthracene; B(a)F, benzo(a)fluoranthene; B(j)F, benzo(j)fluoranthene; B(f)F, benzo(f)fluoranthene; I(1,2,3-cd)P, indeno(1,2,3-cd)pyrene; D(a,h)A, dibenz(a,h)anthracene; and F, fluoranthene.</p> <p>Air Quality Limit Value Regulations 2003 and the equivalent regulations in the Devolved Administrations repeal the earlier statutory instruments transposing the first, second and third daughter Directives.</p> |  |  |

**Table A2 Objectives of the UK Air Quality Strategy, for the Protection of Human Health**

| Pollutant  | Objective   | Compliance Date  |
|--|---|------------------|
| Nitrogen dioxide   | Hourly average concentration should not exceed 200 µg/m <sup>3</sup> (105 ppb) more than 18 times a year. Annual mean concentration should not exceed 40 µg/m <sup>3</sup> (21 ppb).  | 31 December 2005 |
| Particulate matter, expressed as PM <sub>10</sub>  | 24-hour mean concentration should not exceed 50 µg/m <sup>3</sup> more than 35 times a year. Annual mean concentration should not exceed 40 µg/m <sup>3</sup> .   | 31 December 2004 |
|  | <i>Scotland:</i><br>Provisional 24-hour mean concentration should not exceed 50 µg/m <sup>3</sup> more than seven times a year. Provisional annual mean concentration should not exceed 18 µg/m <sup>3</sup> .  | 31 December 2010 |
|  | <i>Northern Ireland, Wales and England (apart from London):</i><br>Provisional 24-hour mean concentration should not exceed 50 µg/m <sup>3</sup> more than seven times a year. Provisional annual mean concentration should not exceed 20 µg/m <sup>3</sup> (equivalent to indicative EU stage II). | 31 December 2010 |
|  | <i>London:</i><br>Provisional 24-hour mean concentration should not exceed 50 µg/m <sup>3</sup> more than 10 times a year. Provisional annual mean concentration should not exceed 23 µg/m <sup>3</sup> .   | 31 December 2010 |
| Benzene  | Running annual mean concentration should not exceed 16.25 µg/m <sup>3</sup> (5 ppb)   | 31 December 2003 |
|  | <i>Scotland &amp; Northern Ireland:</i><br>Running annual mean concentration should not exceed 3.25 µg/m <sup>3</sup> (1.00 ppb)  | 31 December 2010 |
|  | <i>England &amp; Wales:</i><br>Annual mean concentration should not exceed 5 µg/m <sup>3</sup> (1.54 ppb)   | 31 December 2010 |
| 1,3-butadiene  | Running annual mean concentration should not exceed 2.25 µg/m <sup>3</sup> (1 ppb)  | 31 December 2003 |
| Carbon monoxide  | Maximum daily running 8-hour mean concentration should not exceed 10 mg/m <sup>3</sup> (8.6 ppm). In Scotland it is expressed as a running 8-hr mean.   | 31 December 2003 |
| PAHs   | Provisional annual mean concentration of B(a)P should not exceed 0.25 ng/m <sup>3</sup>   | 31 December 2010 |
| Lead (Pb)  | Annual average concentration should not exceed 0.5 µg/m <sup>3</sup> .  | 31 December 2004 |
|  | Annual average concentration should not exceed 0.25 µg/m <sup>3</sup> .   | 31 December 2008 |
| Sulphur dioxide  | Hourly average concentration of 132 ppb (350 µg/m <sup>3</sup> ) not to be exceeded more than 24 times a year.  | 31 December 2004 |
|  | 24-hour average of 47 ppb (125 µg/m <sup>3</sup> ) not to be exceeded more than three times a year.<br>15-minute mean of 100 ppb (266 µg/m <sup>3</sup> ) not to be exceeded more than 35 times a year.   | 31 December 2005 |
| Ozone (O <sub>3</sub> )  | Provisional running 8-hour concentration of 100 µg/m <sup>3</sup> (50 ppb) not to be exceeded more than 10 times a year.  | 31 December 2005 |
| The objectives for benzene, 1,3-butadiene, CO, Pb, NO <sub>2</sub> , PM <sub>10</sub> in 2004 and SO <sub>2</sub> are in The Air Quality (England) Regulations 2000 SI 928 and The Air Quality (England) (Amendment) Regulations 2002 SI 3043 and equivalent regulations for the Devolved Administrations. The PAH, ozone and provisional PM <sub>10</sub> in 2010 objectives are not in the Regulations except for the 2010 annual mean PM <sub>10</sub> objective in Scotland. |   |                  |

**Table A3 Objectives of the Air Quality Strategy Set for the Protection of Vegetation and Ecosystems**

| Pollutant   | Objective  | Compliance Date  |
|---|--|------------------|
| Nitrogen oxides <sup>1</sup>  | Annual average concentration of 30 µg/m <sup>3</sup> (16 ppb)  | 31 December 2000 |
| Sulphur dioxide   | Annual average concentration of 20 µg/m <sup>3</sup> (8 ppb). Winter average concentration (1 October to 31 March) of 20 µg/m <sup>3</sup> (8 ppb) | 31 December 2000 |
| <sup>1</sup> assumes NO <sub>x</sub> is expressed as NO <sub>2</sub> equivalents.<br>These objectives are not in Regulations. |  |                  |

# ANNEX B VEHICLE EMISSIONS

## B1 Vehicle Emission Standards

B1.1 In recognition of the contribution of vehicle emissions to air pollution, measures have been taken to reduce the quantities of pollutants being emitted. The exhaust emission limits for cars – referred to as ‘Euro’ standards from 1990 onwards – are illustrated in Figure B1. The relevant Directives, and the year of implementation at Type Approval are shown on the

x-axis. It should be noted that the ranges associated with the earlier Directives relate to the existence of different limit values according to vehicle weight, engine size or technology, and that the limit values for Euro V vehicles are provisional. More detailed information is given in Tables B1 to B4, which also describe the emission legislation that applies to light-duty commercial vehicles, heavy-duty diesel engines and motorcycles at Type Approval.

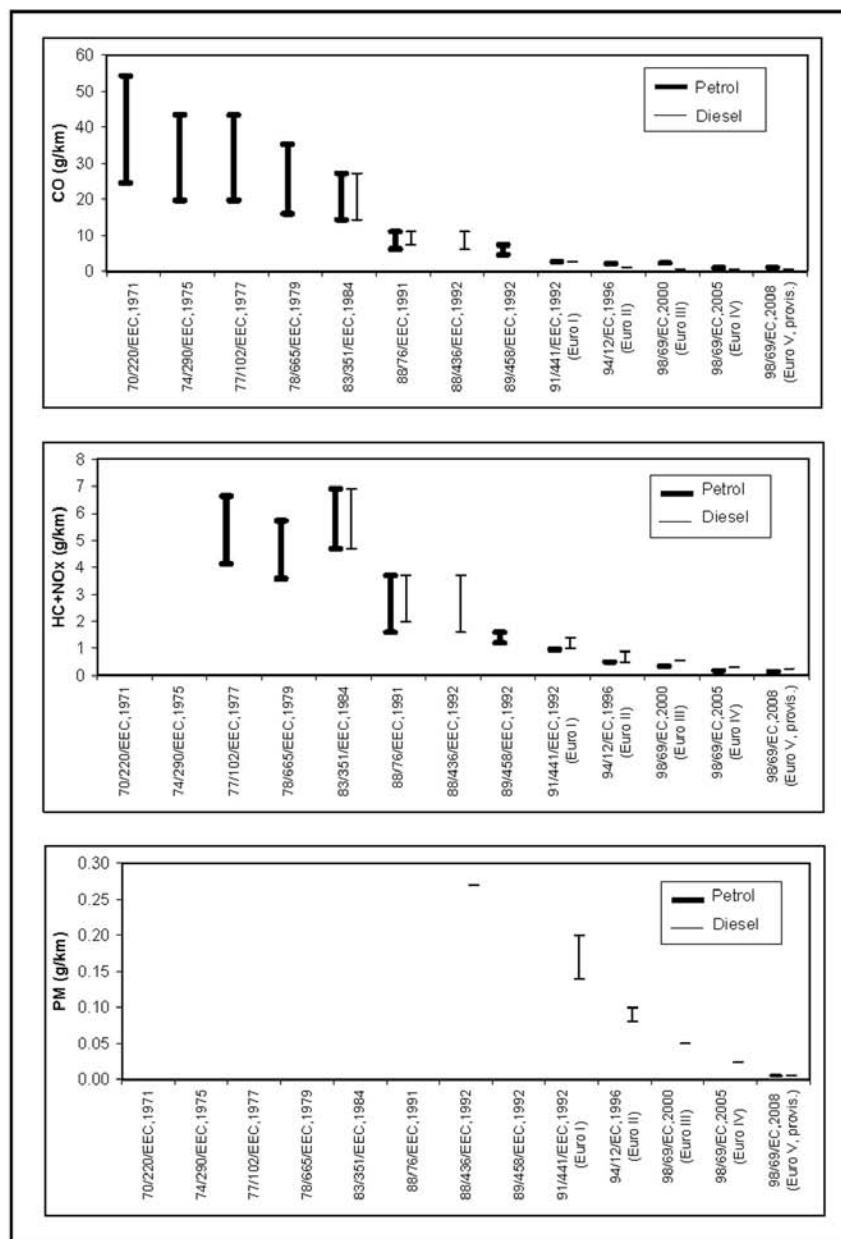

Figure B1 Changes in the Emission Standards for Cars in the EU

**Table B1 Type Approval Emission Standards for Vehicles with at Least Four Wheels Used for the Carriage of Passenger Cars not Exceeding 2.5 Tonnes Laden with up to Six Seats**

| EU Directive                        | Reference mass or engine size | Engine/fuel type        | Limit values (g/km) <sup>1</sup> |              |                 |                    |      | Implementation dates |            |
|-------------------------------------|-------------------------------|-------------------------|----------------------------------|--------------|-----------------|--------------------|------|----------------------|------------|
|                                     |                               |                         | CO                               | HC           | NO <sub>x</sub> | HC+NO <sub>x</sub> | PM   | Type Approval        | In-use     |
| 70/220/EEC                          | <751 kg to >2150 kg           | P                       | 24.68 to 54.29                   | 1.97 to 3.16 |                 |                    |      | 01/09/1971           | 01/09/1972 |
| 74/290/EEC                          | <751 kg to >2150 kg           | P                       | 19.74 to 43.44                   | 1.68 to 2.69 |                 |                    |      | 01/10/1975           | 01/10/1976 |
| 77/102/EEC                          | <751 kg to >2150 kg           | P                       | 19.74 to 43.44                   | 1.68 to 2.69 | 2.47 to 3.95    |                    |      | 01/10/1997           | 01/10/1980 |
| 78/665/EEC                          | <751 kg to >2150 kg           | P                       | 16.04 to 35.29                   | 1.48 to 2.37 | 2.10 to 3.36    |                    |      | 01/10/1979           | 01/10/1981 |
| 83/351/EEC <sup>2</sup>             | <751 kg to >2150 kg           | All                     | 14.31 to 27.15                   |              |                 | 4.69 to 6.91       |      | 01/10/1984           | 01/10/1986 |
| 88/76/EEC <sup>3</sup>              | >2000 cc                      | P                       | 6.17                             |              | 0.86            | 1.6                |      | 01/10/1988           | 01/10/1989 |
|                                     |                               | D                       | 7.40                             |              |                 | 2.0                |      |                      |            |
|                                     | 1400-2000 cc                  | P                       | 7.40                             |              |                 | 2.0                |      | 01/10/1991           | 01/10/1993 |
|                                     |                               | D-IDI                   | 7.40                             |              |                 | 2.0                |      |                      |            |
|                                     |                               | D-DI                    | 7.40                             |              |                 | 2.0                |      |                      |            |
|                                     | <1400 cc                      | P                       | 11.11                            |              | 1.48            | 3.7                |      | 01/10/1990           | 01/10/1991 |
| D                                   |                               | 11.11                   |                                  | 1.48         | 3.7             |                    |      |                      |            |
| 88/436/EEC                          | >2000 cc                      | D-IDI                   | 6.17                             |              | 0.86            | 1.6                | 0.27 | 01/10/1989           | 01/10/1990 |
|                                     |                               | D-DI                    | 6.17                             |              | 0.86            | 1.6                | 0.27 | 01/10/1994           | 01/10/1996 |
|                                     | 1400-2000 cc                  | D-IDI                   | 7.40                             |              |                 | 2.0                | 0.27 | 01/10/1989           | 01/10/1990 |
|                                     |                               | D-DI                    | 7.40                             |              |                 | 2.0                | 0.27 | 01/10/1994           | 01/10/1996 |
|                                     | <1400 cc                      | D-IDI                   | 11.11                            |              | 1.48            | 3.7                | 0.27 | 01/10/1989           | 01/10/1990 |
|                                     |                               | D-DI                    | 11.11                            |              | 1.48            | 3.7                | 0.27 | 01/10/1994           | 01/10/1996 |
| 89/458/EEC                          | <1400 cc                      | P                       | 4.69                             |              |                 | 1.2                |      | 01/07/1992           | 31/12/1992 |
| 91/441/EEC <sup>4</sup><br>(Euro I) | All                           | P                       | 2.72                             |              |                 | 1.0                |      | 01/07/1992           | 31/12/1992 |
|                                     |                               | D-IDI                   | 2.72                             |              |                 | 1.0                | 0.14 |                      |            |
|                                     |                               | D-DI                    | 2.72                             |              |                 | 1.4                | 0.20 |                      |            |
|                                     |                               | D-DI                    | 2.72                             |              |                 | 1.0                | 0.14 | 01/07/1994           | 31/12/1994 |
| 94/12/EC<br>(Euro II)               | All                           | P                       | 2.20                             |              |                 | 0.5                |      | 01/01/1996           | 01/01/1997 |
|                                     |                               | D-IDI                   | 1.00                             |              |                 | 0.7                | 0.08 |                      |            |
|                                     |                               | D-DI                    | 1.00                             |              |                 | 0.9                | 0.10 |                      |            |
|                                     |                               | D-DI                    | 1.00                             |              |                 | 0.7                | 0.08 | 01/10/1999           | 01/10/1999 |
| 98/69/EC<br>(Euro III) <sup>5</sup> |                               | P                       | 2.30                             | 0.20         | 0.15            |                    |      | 01/01/2000           | 01/01/2001 |
|                                     |                               | D                       | 0.64                             |              | 0.50            | 0.56               | 0.05 |                      |            |
|                                     |                               | <i>Cold Test (-7°C)</i> |                                  |              |                 |                    |      |                      |            |
|                                     |                               | P                       | 15.00                            | 1.80         |                 |                    |      | 01/01/2000           | 01/01/2001 |



**Table B1 Type Approval Emission Standards for Vehicles with at Least Four Wheels Used for the Carriage of Passenger Cars not Exceeding 2.5 Tonnes Laden with up to Six Seats (continued)**

| EU Directive   | Reference mass or engine size | Engine/fuel type | Limit values (g/km) <sup>1</sup> |       |                 |                    |                    | Implementation dates |            |
|--|-------------------------------|------------------|----------------------------------|-------|-----------------|--------------------|--------------------|----------------------|------------|
|  |                               |                  | CO                               | HC    | NO <sub>x</sub> | HC+NO <sub>x</sub> | PM                 | Type Approval        | In-use     |
| 98/69/EC<br>(Euro IV)  |                               | P                | 1.00                             | 0.10  | 0.08            |                    |                    | 01/01/2005           | 01/01/2006 |
|  |                               | D                | 0.50                             |       | 0.25            | 0.30               | 0.025              |                      |            |
|  | <i>Cold Test (-7°C)</i>       |                  |                                  |       |                 |                    |                    |                      |            |
|  |                               | P                | 15.00                            | 1.80  |                 |                    |                    | 01/01/2005           | 01/01/2006 |
| Proposed regulation<br>(Euro V)  |                               | P                | 1.00                             | 0.075 | 0.06            |                    | 0.005 <sup>6</sup> | Mid-2008             | Mid-2009   |
|  |                               | D                | 0.50                             |       | 0.20            | 0.25               | 0.005              |                      |            |
|  | <i>Cold Test (-7°C)</i>       |                  |                                  |       |                 |                    |                    |                      |            |
|  |                               | P                | 15.00                            | 1.80  |                 |                    |                    | Mid-2008             | Mid-2009   |
| <p>1 Limits were expressed in units of g/test until Directive 91/441. Values have been divided by 4 (the length of the test cycle in km) for inter-comparison.</p> <p>2 The analytical method for HC measurements was changed. Results using the new method are approximately 2.3 times higher than those previously. Thus, HC + NO<sub>x</sub> limits for 83/351 and later Directives are more severe than might appear from comparison with earlier standards.</p> <p>3 Standards changed to be based on engine capacity, rather than on vehicle weight category. Introduction of the urban test cycle.</p> <p>4 Introduction of a new test cycle, the combined urban and extra-urban test referred to as the EUDC (extra urban drive cycle). In addition the legislation defined a limit for idle CO<sub>2</sub> emissions, zero emissions from the crankcase and a limit on evaporative emissions of hydrocarbons from petrol vehicles.</p> <p>5 Revision to the 91/441 test cycle to exclude the initial 40-second idle, thus tightening the cold start performance requirements.</p> <p>6 Applicable only to vehicles using lean burn DI engines.</p> <p>Glossary: P = petrol, D = diesel, D-DI = diesel direct injection, D-IDI = diesel indirect direction</p> |                               |                  |                                  |       |                 |                    |                    |                      |            |

**Table B2 Type Approval Emission Standards (1998 and After) for Vehicles with at Least Four Wheels Used for the Carriage of Goods not Exceeding 3.5 Tonnes Laden Weight (Includes Car Greater Than 2.5 Tonnes Laden Weight and/or with 7-9 Seats)**

| EU Directive          | Reference mass or engine size | Engine/fuel type | Limit values (g/km) <sup>1</sup> |      |                 |                    |                   | Implementation dates |            |
|-----------------------|-------------------------------|------------------|----------------------------------|------|-----------------|--------------------|-------------------|----------------------|------------|
|                       |                               |                  | CO                               | HC   | NO <sub>x</sub> | HC+NO <sub>x</sub> | PM                | Type Approval        | In-use     |
| 88/76/EEC             | >2000 cc                      | P                | 6.17                             |      | 0.86            | 1.6                |                   | 01/10/1988           | 01/10/1989 |
|                       |                               | D                | 7.40                             |      |                 | 2.0                |                   |                      |            |
|                       | 1400-2000 cc                  | P                | 7.40                             |      |                 | 2.0                |                   | 01/10/1991           | 01/10/1993 |
|                       |                               | D-IDI            | 7.40                             |      |                 | 2.0                |                   |                      |            |
|                       |                               | D-DI             | 7.40                             |      |                 | 2.0                |                   |                      |            |
|                       | <1400 cc                      | P                | 11.11                            |      | 1.48            | 3.7                |                   | 01/10/1990           | 01/10/1991 |
| D                     |                               | 11.11            |                                  | 1.48 | 3.7             |                    |                   |                      |            |
| 88/436/EEC            | >2000 cc                      | D-IDI            | 6.17                             |      | 0.86            | 1.6                | 0.27              | 01/10/1989           | 01/10/1990 |
|                       |                               | D-DI             | 6.17                             |      | 0.86            | 1.6                | 0.27              | 01/10/1994           | 01/10/1996 |
|                       | 1400-2000 cc                  | D-IDI            | 7.40                             |      |                 | 2.0                | 0.27              | 01/10/1989           | 01/10/1990 |
|                       |                               | D-DI             | 7.40                             |      |                 | 2.0                | 0.27              | 01/10/1994           | 01/10/1996 |
|                       | <1400 cc                      | D-IDI            | 11.11                            |      | 1.48            | 3.7                | 0.27              | 01/10/1989           | 01/10/1990 |
|                       |                               | D-DI             | 11.11                            |      | 1.48            | 3.7                | 0.27              | 01/10/1994           | 01/10/1996 |
| 89/458/EEC            | <1400 cc                      | P                | 4.69                             |      |                 | 1.2                |                   | 01/07/1992           | 31/12/1992 |
| 93/59/EEC<br>(Euro I) | <1250 kg                      | P & D-IDI        | 2.72                             |      |                 | 0.97               | 0.14 <sup>1</sup> | 01/10/1993           | 01/10/1994 |
|                       |                               | D-DI             | 2.72                             |      |                 | 0.97               | 0.14              | 01/10/1994           | 01/10/1995 |
|                       | 1250-1700 kg                  | P & D-IDI        | 5.17                             |      |                 | 1.4                | 0.19 <sup>1</sup> | 01/10/1993           | 01/10/1994 |
|                       |                               | D-DI             | 5.17                             |      |                 | 1.4                | 0.19              | 01/10/1994           | 01/10/1995 |
|                       | 1700-3500 kg                  | P & D-IDI        | 6.90                             |      |                 | 1.7                | 0.25 <sup>1</sup> | 01/10/1993           | 01/10/1994 |
|                       |                               | D-DI             | 6.90                             |      |                 | 1.7                | 0.25              | 01/10/1994           | 01/10/1995 |
| 96/69/EC<br>(Euro II) | <1250 kg                      | P                | 2.20                             |      |                 | 0.5                |                   | 01/01/1998           | 01/01/1999 |
|                       |                               | D-IDI            | 1.00                             |      |                 | 0.7                | 0.08              |                      |            |
|                       |                               | D-DI             | 1.00                             |      |                 | 0.7                | 0.08              |                      |            |
|                       | 1250-1700 kg                  | P                | 4.00                             |      |                 | 0.65               |                   |                      |            |
|                       |                               | D-IDI            | 1.25                             |      |                 | 1.0                | 0.12              |                      |            |
|                       |                               | D-DI             | 1.25                             |      |                 | 1.0                | 0.12              |                      |            |
|                       | 1700-3500 kg                  | P                | 5.00                             |      |                 | 0.8                |                   |                      |            |
|                       |                               | D-IDI            | 1.50                             |      |                 | 1.2                | 0.17              |                      |            |
|                       |                               | D-DI             | 1.50                             |      |                 | 1.2                | 0.17              |                      |            |

**Table B2 Type Approval Emission Standards (1998 and After) for Vehicles with at Least Four Wheels Used for the Carriage of Goods not Exceeding 3.5 Tonnes Laden Weight (Includes Car Greater Than 2.5 Tonnes Laden Weight and/or with 7-9 Seats) (continued)**

| EU Directive  | Reference mass or engine size | Engine/fuel type | Limit values (g/km) <sup>1</sup> |       |                 |                    |                    | Implementation dates |            |
|---|-------------------------------|------------------|----------------------------------|-------|-----------------|--------------------|--------------------|----------------------|------------|
|   |                               |                  | CO                               | HC    | NO <sub>x</sub> | HC+NO <sub>x</sub> | PM                 | Type Approval        | In-use     |
| 98/69/EC<br>(Euro III)  | <1305 kg                      | P                | 2.30                             | 0.20  | 0.15            |                    |                    | 01/01/2000           | 01/01/2001 |
|   |                               | D                | 0.64                             |       | 0.5             | 0.56               | 0.05               |                      |            |
|   | 1305-1760 kg                  | P                | 4.17                             | 0.25  | 0.18            |                    |                    |                      |            |
|   |                               | D                | 0.80                             |       | 0.65            | 0.72               | 0.07               |                      |            |
|   | 1760-3500 kg                  | P                | 5.22                             | 0.29  | 0.21            |                    |                    |                      |            |
|   |                               | D                | 0.95                             |       | 0.78            | 0.86               | 0.1                |                      |            |
|   | <i>Cold Test (-7°C)</i>       |                  |                                  |       |                 |                    |                    |                      |            |
| <1305 kg  | P                             | 15.00            | 1.80                             |       |                 |                    | 01/01/2000         | 01/01/2001           |            |
| 98/69/EC<br>(Euro IV)   | <1305 kg                      | P                | 1.00                             | 0.10  | 0.08            |                    |                    | 01/01/2005           | 01/01/2006 |
|   |                               | D                | 0.50                             |       | 0.25            | 0.3                | 0.025              |                      |            |
|   | 1305-1760 kg                  | P                | 1.81                             | 0.13  | 0.10            |                    |                    | 01/01/2006           | 01/01/2007 |
|   |                               | D                | 0.63                             |       | 0.33            | 0.39               | 0.04               |                      |            |
|   | 1760-3500 kg                  | P                | 2.27                             | 0.16  | 0.11            |                    |                    | 01/01/2006           | 01/01/2007 |
|   |                               | D                | 0.74                             |       | 0.39            | 0.46               | 0.06               |                      |            |
|   | <i>Cold Test (-7°C)</i>       |                  |                                  |       |                 |                    |                    |                      |            |
| <1305 kg  | P                             | 15.00            | 1.80                             |       |                 |                    | 01/01/2005         | 01/01/2006           |            |
| Proposed regulation<br>(Euro V)   | <1305 kg                      | P                | 1.0                              | 0.075 | 0.06            |                    | 0.0052             | Mid-2008             | Mid-2009   |
|   |                               | D                | 0.50                             |       | 0.20            | 0.25               | 0.005 <sup>2</sup> |                      |            |
|   | 1305-1760 kg                  | P                | 1.81                             | 0.10  | 0.075           |                    | 0.0052             |                      |            |
|   |                               | D                | 0.63                             |       | 0.26            | 0.32               | 0.005 <sup>2</sup> |                      |            |
|   | 1760-3500 kg                  | P                | 2.27                             | 0.12  | 0.082           |                    | 0.0052             |                      |            |
|   |                               | D                | 0.74                             |       | 0.31            | 0.38               | 0.005 <sup>2</sup> |                      |            |
|   | <i>Cold Test (-7°C)</i>       |                  |                                  |       |                 |                    |                    |                      |            |
| <1305 kg  | P                             | 15               | 1.8                              |       |                 |                    | Mid-2008           | Mid-2009             |            |
| 1305-1760 kg  | P                             | 24               | 2.7                              |       |                 |                    |                    |                      |            |
| 1760-3500 kg  | P                             | 30               | 3.2                              |       |                 |                    |                    |                      |            |
| <p>1. Diesel IDI only.<br/>2. Applicable only to vehicles using lean burn DI engines.</p> <p>Glossary: P = petrol D = diesel D-DI = diesel direct injection D-IDI = diesel indirect direction</p> |                               |                  |                                  |       |                 |                    |                    |                      |            |

**Table B3 Type Approval Emission Standards for Vehicles Used for the Carriage of Goods and Exceeding 3.5 Tonnes Laden Weight**

| EU Directive             | Vehicle category                       | Test <sup>1</sup> | Limit values (g/km)          |      |                 |                    |       |       | Implementation dates              |            |
|--------------------------|--|-------------------|------------------------------|------|-----------------|--------------------|-------|-------|-----------------------------------|------------|
|                          |  |                   | CO                           | HC   | NO <sub>x</sub> | HC+NO <sub>x</sub> | PM    | Smoke | Type Approval                     | In-use     |
| 72/306/EEC               | All                                    | FAS               | Nominal Flow: 42 litres/sec  |      |                 |                    |       | 2.260 | Within 18 months of<br>02/08/1972 |            |
|                          |  |                   | Nominal Flow: 100 litres/sec |      |                 |                    |       | 1.495 |                                   |            |
|                          |  |                   | Nominal Flow: 200 litres/sec |      |                 |                    |       | 1.065 |                                   |            |
| 88/77/EEC                | All                                    | 13-Mode           | 11.20                        | 2.40 | 14.40           |                    |       |       | 01/07/1988                        | 01/10/1990 |
| 91/542/EEC               | > 86kW                                 |                   | 4.50                         | 1.10 | 8.00            |                    | 0.36  |       | 01/07/1992                        | 01/10/1993 |
| (Euro I)                 | >= 86kW                                |                   | 4.50                         | 1.10 | 8.00            |                    | 0.612 |       |                                   |            |
| 91/542/EEC<br>(Euro II)  | All                                    |                   | 4.00                         | 1.10 | 7.00            |                    | 0.15  |       | 01/10/1995                        | 01/10/1996 |
| 1999/96/EC<br>(Euro III) | >= 0.75dm <sup>3</sup><br>per cylinder | ESC/ELR           | 2.10                         | 0.66 | 5.00            |                    | 0.1   | 0.8   | 01/10/2000                        | 01/10/2001 |
|                          |  | ETC               | 5.45                         | 0.78 | 5.00            | 1.6                | 0.16  |       |                                   |            |
|                          | < 0.75dm <sup>3</sup><br>per cylinder  | ESC/ELR           | 2.10                         | 0.66 | 5.00            |                    | 0.13  | 0.8   |                                   |            |
|                          |  | ETC               | 5.45                         | 0.78 | 5.00            | 1.6                | 0.21  |       |                                   |            |
| 1999/96/EC<br>(Euro IV)  | All                                    | ESC/ELR           | 1.50                         | 0.46 | 3.50            |                    | 0.02  | 0.5   | 01/10/2005                        | 01/10/2006 |
|                          |  | ETC               | 4.00                         | 0.55 | 3.50            | 1.1                | 0.03  |       |                                   |            |
| 1999/96/EC<br>(Euro V)   | All                                    | ESC/ELR           | 1.50                         | 0.46 | 2.00            |                    | 0.02  | 0.5   | 01/10/2008                        | 01/10/2009 |
|                          |  | ETC               | 4.00                         | 0.55 | 2.00            | 1.1                | 0.03  |       |                                   |            |
| 1999/96/EC<br>(EEV)      | All                                    | ESC/ELR           | 1.50                         | 0.25 | 2.00            |                    | 0.02  | 0.15  | Voluntary                         |            |
|                          |  | ETC               | 3.00                         | 0.40 | 2.00            | 0.65               | 0.02  |       |                                   |            |

1 Test cycles: ESC – cycle consisting of 13 steady state modes, ELR – cycle consisting of a sequence of load steps at constant engine speeds, ETC – cycle consisting of 1800 second-by-second transient modes. Smoke opacity as determined on the ELR test.

Glossary:  
 EEV = Environmentally enhanced vehicle (operating on alternative fuels)  
 FAS = Free Acceleration Smoke test  
 CH<sub>4</sub> = methane.

**Table B4 Type Approval Emission Standards for Motorcycles (Two-Wheel, Three-Wheel)**

| EU Directive   | Engine type | Mass/capacity | Limit values (g/km)     |                       |                 | Implementation dates |            |
|--|-------------|---------------|-------------------------|-----------------------|-----------------|----------------------|------------|
|  |             |               | CO                      | HC                    | NO <sub>x</sub> | Type Approval        | In-use     |
| ECE R40-00   | 2-stroke    | <=100 kg      | 16                      | 10                    |                 | 1979                 |            |
|  | 4-stroke    |               | 25                      | 7                     |                 |                      |            |
|  | 2-stroke    | 100-300 kg    | $16+24*(m-100)/200$     | $10+5(m-100)/200$     |                 |                      |            |
|  | 4-stroke    |               | $25+25*(m-100)/200$     | $7+3*(m-100)/200$     |                 |                      |            |
|  | 2-stroke    | >300 kg       | 40                      | 14                    |                 |                      |            |
|  | 4-stroke    |               | 50                      | 10                    |                 |                      |            |
| ECE R40-01   | 2-stroke    | <=100 kg      | 12.8                    | 8                     |                 | 1988                 |            |
|  | 4-stroke    |               | 17.5                    | 4.2                   |                 |                      |            |
|  | 2-stroke    | 100-300 kg    | $12.8+19.2*(m-100)/200$ | $8+4*(m-100)/200$     |                 |                      |            |
|  | 4-stroke    |               | $17.5+17.5*(m-100)/200$ | $4.2+1.8*(m-100)/200$ |                 |                      |            |
|  | 2-stroke    | >300 kg       | 32                      | 12                    |                 |                      |            |
|  | 4-stroke    |               | 35                      | 6                     |                 |                      |            |
| 97/24/EC<br>Stage I  | 2-stroke    | All           | 8                       | 4                     | 0.1             | 17/6/1999            | 17/6/2000  |
|  | 4-stroke    | All           | 13                      | 3                     | 0.3             |                      |            |
| 97/24/EC<br>Stage II<br>(amended in<br>Directive<br>2002/51/EC)  | 2-stroke    | All           | 5.5                     |                       | 0.3             | 01/04/2003           | 01/04/2004 |
|  |             | <150cc        |                         | 1.2                   |                 |                      |            |
|  | >150cc      |               | 1                       |                       |                 |                      |            |
|  | 4-stroke    | All           | 5.5                     |                       | 0.3             |                      |            |
|  |             | <150cc        |                         | 1.2                   |                 |                      |            |
|  |             | >150cc        |                         | 1                     |                 |                      |            |
| 97/24/EC<br>Stage III<br>(amended in<br>Directive<br>2002/51/EC) | 2-stroke    | All           | 2                       |                       | 0.15            | 01/01/2006           | 01/01/2007 |
|  |             | <150cc        |                         | 0.8                   |                 |                      |            |
|  |             | >150cc        |                         | 0.3                   |                 |                      |            |
|  | 4-stroke    | All           | 2                       |                       | 0.15            |                      |            |
|  |             | <150cc        |                         | 0.8                   |                 |                      |            |
|  |             | >150cc        |                         | 0.3                   |                 |                      |            |

B1.2 Following Type Approval, all production vehicles must comply with 'Conformity of Production' standards, which are, in some cases, slightly less stringent than the Type Approval limits. There is evidence, though, that emissions from vehicles in use do not remain at the design levels, especially if a vehicle is poorly maintained.

B1.3 As a result of this legislation, subsequent improvements in emission-control technology, and other measures to control vehicle emissions, the emissions of the regulated pollutants from each vehicle have decreased substantially during the last few decades. Reductions in emissions will continue in the future, as new vehicles built to more exacting standards replace older, more polluting types.

B1.4 The general reduction of emissions per vehicle with time is of great importance in the appraisal of air quality impacts. The numbers of ‘low-emission’ vehicles in the fleet and the total numbers of vehicles on the road are likely to be more important determinants of emission and pollution levels than factors relating to the design and management of the road network. But other factors are nevertheless important. The way in which a vehicle is operated does affect its emissions, and the precise location of a road will determine the severity of local impacts. These are clearly factors that network design and management can influence.

## B2 Vehicle Emission Factors

### Background

B2.1 The exhaust emission characteristics of the UK light-duty vehicle fleet have been assessed through a series of large-scale surveys, the first of which was conducted in 1968. Follow-up surveys have taken place

periodically to provide continuing information on emissions from the evolving vehicle fleet. The last major revision to the UK emission factor database was issued by DfT in 2002.

B2.2 Measurements have shown that high emissions (in g/km) tend to occur at low speeds (e.g. in congested traffic) and at high speeds (e.g. on motorways). Figure B2 shows a series of graphs which give typical emission factors for petrol-engined Euro I to Euro IV vehicles as a function of average speed. Other types of engine and vehicle respond differently to changes in average speed. It should also be noted that trips having very different operational characteristics can have the same average speed. All the types of operation associated with a given average speed cannot be accounted for by the use of a single emission factor. Consequently, a particular vehicle operated under specific circumstances may have an emission factor which is considerably different from the average. For example, emissions under ‘stop-start’ driving conditions tend to be higher than those when vehicles are driven more smoothly.

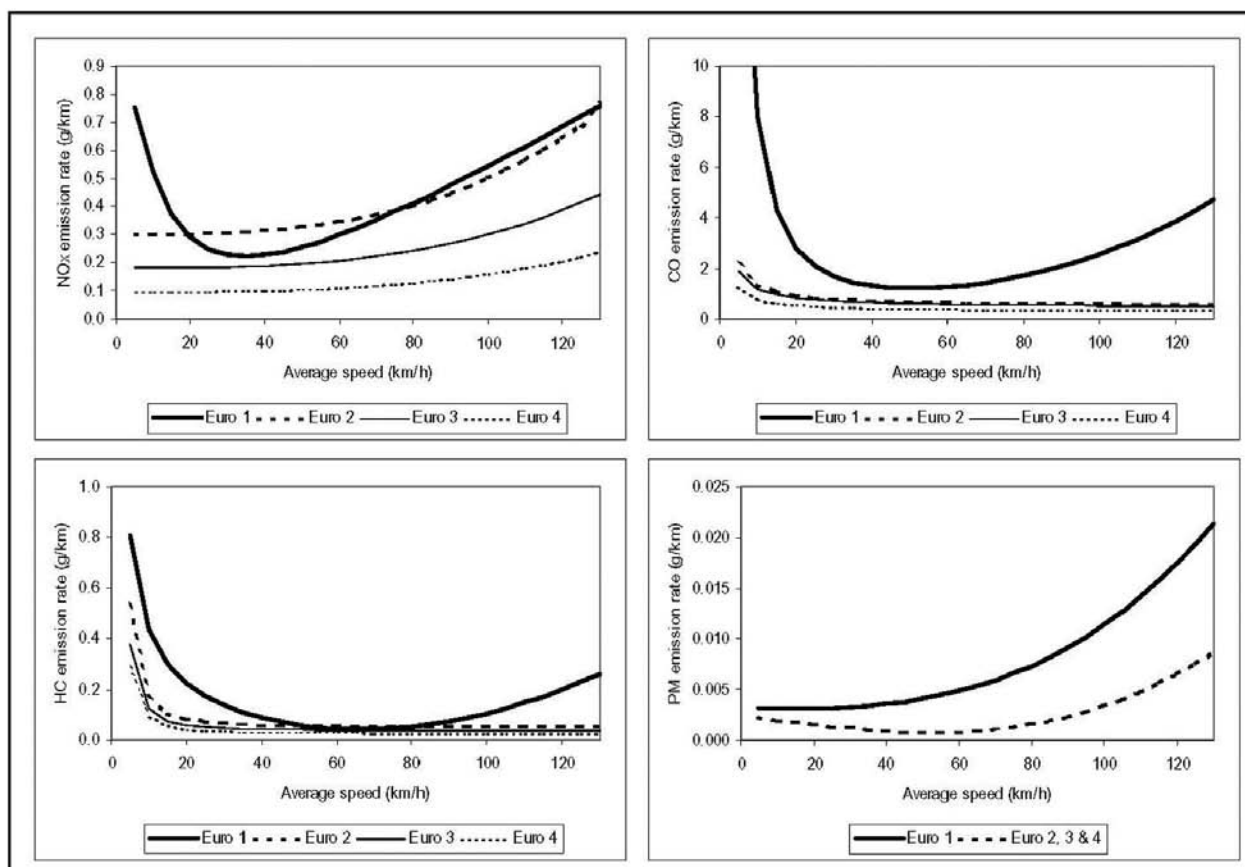

Figure B2 Typical Speed-Related Emission Factors (Petrol Cars, Engine Size 1.4-2.0 Litres)

**B2.3** An engine that is cold is inefficient, and extra fuel has to be supplied for satisfactory operation. This significantly increases the 'engine out' rates of emission of carbon monoxide (CO) and hydrocarbons (HC), as well as the fuel consumption. Furthermore, the performance of a catalyst is affected. Conventional three-way catalysts do not begin to work effectively until their temperature reaches a 'light-off' value of around 300°C, and also require an accurately controlled exhaust composition. Tests on catalyst-equipped cars have shown that emissions of CO and HC can increase by an order of magnitude during cold starting relative to emissions during thermally stable operation. Whilst cold start effects can be significant on local roads in urban areas, they are not incorporated into the DMRB screening tool as this was developed primarily for the trunk road network. For situations where cold starts could have a significant impact on local air quality, such as car parks and dense residential areas, supplementary sensitivity assessments are recommended.

#### **Development of Emission Factors for NO<sub>x</sub>, PM, CO and HC**

**B2.4 Petrol cars.** The emission functions for pre-Euro I (Regulation ECE 15), Euro I and Euro II vehicles were all derived from measurements.

**B2.5 Diesel cars.** The emission functions for pre-Euro I, Euro I and Euro II vehicles were all derived from measurements.

**B2.6 Petrol LGVs.** The emission functions for pre-Euro I vehicles were drawn from a 1998 TRL database for small and medium-sized LGVs, with the Euro I functions being taken from the 2001 database. Emission functions for Euro II petrol LGVs were not available, and so they were assumed to be the same as those for a medium-sized petrol car. The emission functions for Euro III and IV vehicles were based on emission reduction scaling factors applied to the equations for Euro II vehicles. PM emission functions for Euro I and II vehicles were assumed to be the same as those for a medium-sized petrol car. Since PM emissions from petrol vehicles are not regulated, it was assumed that PM emissions from Euro III and Euro IV vehicles would remain at Euro II levels.

**B2.7 Diesel LGVs.** The emission functions for pre-Euro I vehicles were obtained from the 1998 TRL database for medium- and large-sized LGVs, and the Euro I emission functions were taken from the 2001 database. Factors for Euro II diesel LGVs were not available. Emission coefficients for Euro II diesel LGVs were assumed to be the same as for Euro I on the basis that no further reduction in emissions was necessary. For oxides of nitrogen (NO<sub>x</sub>), a slight reduction in emissions was required from Euro I to meet the Euro II limits. Therefore, the Euro I coefficients were adopted with a 0.95 scaling factor for Euro II vehicles. The Euro III and IV emission functions (including PM) were based on emission reduction scaling factors applied to the functions for Euro II.

**B2.8 HGVs and buses.** The emission functions for pre-Euro I, Euro I, and Euro II vehicles were all drawn from measurements. The pre-Euro I functions were taken from the 1998 TRL database, and the Euro I and Euro II functions were taken from the 2001 TRL database. Euro III and IV emission functions were based on emission reduction scaling factors applied to the equations for Euro II. The scaling factors were drawn from COPERT III<sup>21</sup>. Although measurements on heavy-duty vehicles have been conducted in recent years, these have not yet been assimilated in the emission factor equations.

#### **Development of Emission Factors for Benzene and 1,3-Butadiene**

**B2.9** The emission coefficients for benzene and 1,3-butadiene were the same as those for total hydrocarbons, except for the use of a scaling coefficient reflecting the mass fraction of these two species in the total hydrocarbon emissions from different vehicle types. The mass fractions of benzene and 1,3-butadiene were based on the non-methane volatile organic compounds (NMVOC) emission speciation given in COPERT III. In deriving species fractions from the total hydrocarbon emission functions given by TRL, it was necessary to account for the amount of methane in the HC emissions, as the COPERT values apply to NMVOCs. The methane components of the total HC emissions from each vehicle type were calculated using the COPERT III emission factors for methane.

---

<sup>21</sup> COPERT III Methodology and Emission Factors. Final Draft Report. European Environment Agency, European Topic Centre on Air Emissions. 1999.

### Development of Emission Functions for Carbon

B2.10 The carbon calculations are based upon DfT's transport analysis guidance website Web-TAG<sup>22</sup> (Unit 3.5.6, Section 1.3, Vehicle Operating Costs), which deals with vehicle operating costs. Functions are given in Web-TAG to enable fuel consumption (in litres/km) to be calculated as a function of average speed for seven vehicle categories: petrol car, diesel car, petrol LGV, diesel LGV, OGV1<sup>23</sup>, OGV2 and PSV<sup>24</sup>. Carbon emission values were calculated from the fuel consumption values using average densities for petrol and diesel and carbon proportions by mass.

### Other Fuel and Technology Factors Affecting Emissions

B2.11 The emission function projections combine the effects of the penetration of improved fuels and other technologies on the baseline emissions from the fleet. The early introduction of ultra-low sulphur petrol and diesel (100% by 2001) into the national fleet is taken into account. Many bus fleets had converted to ultra-low sulphur diesel (ULSD) as early as 1997, and this is also accounted for. The impacts these fuels would have on emissions from existing vehicles in the fleet was based on empirical formulae from EPEFE<sup>25</sup> on the relationship between emissions and fuel quality, combined with information drawn from MEET, the World-Wide Fuel Charter reports, and various reports prepared by Millbrook and London Transport Buses on the effects of fuel quality on emissions from heavy-duty vehicles<sup>26</sup>.

B2.12 The retrofitting of particulate traps and oxidation catalyst on some heavy-duty diesel vehicles is accounted for on the basis of information from DfT in 2001 on their likely uptake. Again, the assumptions on their effects on emissions and their fleet uptake was that used for the Air Quality Strategy forecasts.

B2.13 The effect of the benzene content of petrol on exhaust emissions of benzene required particular attention. According to the UK Petroleum Industries Association (UKPIA), a very significant decrease in benzene content of UK petrol (76%) occurred in 2000 in order to meet the lower EU limit of 1% introduced that year. Equations from EPEFE and MEET were used

to derive factors reflecting the effect of reduced benzene content on benzene emissions from catalyst cars. No such information is available for non-catalyst cars. However, on the basis of fundamental combustion chemistry modelling and the substantial decreases in ambient benzene concentrations observed in early 2000 at a number of Defra's Automatic Urban and Rural Network (AURN) monitoring sites, it was concluded that the reductions in benzene content of petrol led to a proportional reduction in benzene emissions from non-catalyst cars. This is represented with an emission reduction scaling factor for this class of vehicle.

B2.14 Carbon emissions from the newest vehicles will be influenced by the general improvements in technology designed to increase fuel economy and, for cars in particular, by a voluntary agreement between the European Automobile Manufacturers Association and the EU to reduce emissions, as well as changes in fuel composition (e.g. the wider adoption of alternative fuels). Web-TAG also provides emission scaling factors to take account of future improvements in vehicle technology and changes in fuel composition.

### B3 Emission Factor Equations

B3.1 For the pollutants: carbon monoxide, total hydrocarbons, total oxides of nitrogen, particulate matter, benzene and 1,3-butadiene, the equation expressing pollutant emission rates as a function of average vehicle speed takes the standard form:

$$E = (a + b.v + c.v^2 + d.v^e + f.\ln(v) + g.v^3 + h/v + i/v^2 + j/v^3).x$$

Where: *E* is the emission rate expressed in g/km  
*v* is the average vehicle speed in km/hr  
*a* to *j*, and *x* are coefficients

B3.2 The coefficients are given for each pollutant and a wide range of vehicle types in Tables B5 to B10. The valid speed ranges are 5 km/h to 130 km/h for light-duty vehicles, and 5 km/h to 100 km/h for heavy-duty vehicles.

B3.3 The DMRB emission rates are the same as those in the NAEI for all pollutants except carbon.

<sup>22</sup> Available at <http://www.webtag.org.uk/>

<sup>23</sup> OGV = 'other goods vehicles. For the purposes of the CO<sub>2</sub> calculation, OGV1 and OGV2 were assumed to be equivalent to rigid HGVs and articulated HGVs respectively.

<sup>24</sup> PSV = public service vehicles (buses and coaches).

<sup>25</sup> EPEFE = European Programme on Emissions, Fuels and Engine Technologies.

<sup>26</sup> UK road transport emission projections, see <http://www.naei.org.uk/reports.php> for further details.



Table B5 Emission Function Coefficients for Carbon Monoxide

| Legislation class  | Engine size or vehicle configuration | Coefficients |         |           |   |   |   |            |       |     |       |      | Valid speed range (km/h) |
|--------------------|--------------------------------------|--------------|---------|-----------|---|---|---|------------|-------|-----|-------|------|--------------------------|
|                    |                                      | a            | b       | c         | d | e | f | g          | h     | i   | j     | x    |                          |
| <i>Petrol car</i>  |                                      |              |         |           |   |   |   |            |       |     |       |      |                          |
| Pre-ECE            | < 1.4 l                              | 13.6         | -0.169  | 0         | 0 | 0 | 0 | 0.00000926 | 158   | 0   | 0     | 2.62 | 5 – 130                  |
|                    | 1.4 - 2.0 l                          | 9.53         | -0.118  | 0         | 0 | 0 | 0 | 0.0000062  | 179   | 0   | 0     | 2.62 |                          |
|                    | > 2.0 l                              | 9.71         | -0.243  | 0.0018    | 0 | 0 | 0 | 0          | 244   | 0   | 0     | 2.62 |                          |
| ECE 15.00          | < 1.4 l                              | 13.6         | -0.169  | 0         | 0 | 0 | 0 | 0.00000926 | 158   | 0   | 0     | 1.87 |                          |
|                    | 1.4 - 2.0 l                          | 9.53         | -0.118  | 0         | 0 | 0 | 0 | 0.0000062  | 179   | 0   | 0     | 1.87 |                          |
|                    | > 2.0 l                              | 9.71         | -0.243  | 0.0018    | 0 | 0 | 0 | 0          | 244   | 0   | 0     | 1.87 |                          |
| ECE 15.01          | < 1.4 l                              | 13.6         | -0.169  | 0         | 0 | 0 | 0 | 0.00000926 | 158   | 0   | 0     | 1.87 |                          |
|                    | 1.4 - 2.0 l                          | 9.53         | -0.118  | 0         | 0 | 0 | 0 | 0.0000062  | 179   | 0   | 0     | 1.87 |                          |
|                    | > 2.0 l                              | 9.71         | -0.243  | 0.0018    | 0 | 0 | 0 | 0          | 244   | 0   | 0     | 1.87 |                          |
| ECE 15.02          | < 1.4 l                              | 13.6         | -0.169  | 0         | 0 | 0 | 0 | 0.00000926 | 158   | 0   | 0     | 1.55 |                          |
|                    | 1.4 - 2.0 l                          | 9.53         | -0.118  | 0         | 0 | 0 | 0 | 0.0000062  | 179   | 0   | 0     | 1.55 |                          |
|                    | > 2.0 l                              | 9.71         | -0.243  | 0.0018    | 0 | 0 | 0 | 0          | 244   | 0   | 0     | 1.55 |                          |
| ECE 15.03          | < 1.4 l                              | 13.6         | -0.169  | 0         | 0 | 0 | 0 | 0.00000926 | 158   | 0   | 0     | 1.62 |                          |
|                    | 1.4 - 2.0 l                          | 9.53         | -0.118  | 0         | 0 | 0 | 0 | 0.0000062  | 179   | 0   | 0     | 1.62 |                          |
|                    | > 2.0 l                              | 9.71         | -0.243  | 0.0018    | 0 | 0 | 0 | 0          | 244   | 0   | 0     | 1.62 |                          |
| ECE 15.04          | < 1.4 l                              | 13.6         | -0.169  | 0         | 0 | 0 | 0 | 0.00000926 | 158   | 0   | 0     | 1    |                          |
|                    | 1.4 - 2.0 l                          | 9.53         | -0.118  | 0         | 0 | 0 | 0 | 0.0000062  | 179   | 0   | 0     | 1    |                          |
|                    | > 2.0 l                              | 9.71         | -0.243  | 0.0018    | 0 | 0 | 0 | 0          | 244   | 0   | 0     | 1    |                          |
| Euro I             | < 1.4 l                              | 4.23         | -0.0867 | 0         | 0 | 0 | 0 | 0.00000801 | 0     | 360 | 0     | 1    |                          |
|                    | 1.4 - 2.0 l                          | 0.612        | 0       | 0         | 0 | 0 | 0 | 0.00000184 | 0     | 980 | -2383 | 1    |                          |
|                    | > 2.0 l                              | 0.0423       | 0       | 0.000145  | 0 | 0 | 0 | 0          | 112   | 0   | 0     | 1    |                          |
| Euro II            | < 1.4 l                              | 0.385        | -0.0007 | 0         | 0 | 0 | 0 | 0          | 44.2  | 0   | 0     | 1    |                          |
|                    | 1.4 - 2.0 l                          | 0.51         | 0       | 0         | 0 | 0 | 0 | 0          | 8.01  | 0   | 0     | 1    |                          |
|                    | > 2.0 l                              | -0.241       | 0.00166 | 0         | 0 | 0 | 0 | 0          | 12.8  | 0   | 0     | 1    |                          |
| Euro III           | < 1.4 l                              | 0.385        | -0.0007 | 0         | 0 | 0 | 0 | 0          | 44.2  | 0   | 0     | 0.9  |                          |
|                    | 1.4 - 2.0 l                          | 0.51         | 0       | 0         | 0 | 0 | 0 | 0          | 8.01  | 0   | 0     | 0.9  |                          |
|                    | > 2.0 l                              | -0.241       | 0.00166 | 0         | 0 | 0 | 0 | 0          | 12.8  | 0   | 0     | 0.9  |                          |
| Euro IV            | < 1.4 l                              | 0.385        | -0.0007 | 0         | 0 | 0 | 0 | 0          | 44.2  | 0   | 0     | 0.6  |                          |
|                    | 1.4 - 2.0 l                          | 0.51         | 0       | 0         | 0 | 0 | 0 | 0          | 8.01  | 0   | 0     | 0.6  |                          |
|                    | > 2.0 l                              | -0.241       | 0.00166 | 0         | 0 | 0 | 0 | 0          | 12.8  | 0   | 0     | 0.6  |                          |
| <i>Diesel cars</i> |                                      |              |         |           |   |   |   |            |       |     |       |      |                          |
| Pre-Euro I         | < 2.0 l                              | 0.478        | -0.0068 | 0.000045  | 0 | 0 | 0 | 0          | 16.9  | 0   | 0     | 1    | 5 – 130                  |
|                    | > 2.0 l                              | 0.599        | -0.0056 | 0.000026  | 0 | 0 | 0 | 0          | 12    | 0   | 0     | 1    |                          |
| Euro I             | < 2.0 l                              | 0.499        | -0.0098 | 0.000065  | 0 | 0 | 0 | 0          |       | 200 | -777  | 1    |                          |
|                    | > 2.0 l                              | 0.0373       |         | -0.000034 |   |   |   | 3.16e-07   | 8.82  | 0   | 0     | 1    |                          |
| Euro II            | < 2.0 l                              | 0.632        | -0.0135 | 0.000075  | 0 | 0 | 0 | 0          | 2.38  | 0   | 0     | 1    |                          |
|                    | > 2.0 l                              | 0.624        | -0.0128 | 0.0000697 | 0 | 0 | 0 | 0          | 0.139 | 0   | 0     | 1    |                          |
| Euro III           | < 2.0 l                              | 0.632        | -0.0135 | 0.000075  | 0 | 0 | 0 | 0          | 2.38  | 0   | 0     | 0.6  |                          |
|                    | > 2.0 l                              | 0.624        | -0.0128 | 0.0000697 | 0 | 0 | 0 | 0          | 0.139 | 0   | 0     | 0.6  |                          |
| Euro IV            | < 2.0 l                              | 0.632        | -0.0135 | 0.000075  | 0 | 0 | 0 | 0          | 2.38  | 0   | 0     | 0.6  |                          |
|                    | > 2.0 l                              | 0.624        | -0.0128 | 0.0000697 | 0 | 0 | 0 | 0          | 0.139 | 0   | 0     | 0.6  |                          |

**Table B5 Emission Function Coefficients for Carbon Monoxide (continued)**

| Legislation class  | Engine size or vehicle configuration | Coefficients |         |           |   |   |   |            |       |      |       |      | Valid speed range (km/h) |
|--------------------|--------------------------------------|--------------|---------|-----------|---|---|---|------------|-------|------|-------|------|--------------------------|
|                    |                                      | a            | b       | c         | d | e | f | g          | h     | i    | j     | x    |                          |
| <i>Petrol LGV</i>  |                                      |              |         |           |   |   |   |            |       |      |       |      |                          |
| Pre-Euro I         | All                                  | 20.52        | -0.141  | -0.005328 | 0 | 0 | 0 | 0.0000674  | 143.2 | 77.4 | 0     | 1    | 5 – 130                  |
| Euro I             | All                                  | -0.447       | 0       | 0         | 0 | 0 | 0 | 9.29e-07   | 140   | 0    | 0     | 1    |                          |
| Euro II            | All                                  | 0.51         | 0       | 0         | 0 | 0 | 0 | 0          | 8.01  | 0    | 0     | 1    |                          |
| Euro III           | All                                  | 0.51         | 0       | 0         | 0 | 0 | 0 | 0          | 8.01  | 0    | 0     | 0.9  |                          |
| Euro IV            | All                                  | 0.51         | 0       | 0         | 0 | 0 | 0 | 0          | 8.01  | 0    | 0     | 0.6  |                          |
| <i>Diesel LGV</i>  |                                      |              |         |           |   |   |   |            |       |      |       |      |                          |
| Pre-Euro I         | All                                  | 1.642        | -0.0191 | 0.000005  | 0 | 0 | 0 | 0.0000012  | 4.312 | 0    | 0     | 1    | 5 – 130                  |
| Euro I             | All                                  | -1.49        | 0.0181  | 0         | 0 | 0 | 0 | 0          | 52.5  | -140 | 0     | 1    |                          |
| Euro II            | All                                  | -1.49        | 0.0181  | 0         | 0 | 0 | 0 | 0          | 52.5  | -140 | 0     | 1    |                          |
| Euro III           | All                                  | -1.49        | 0.0181  | 0         | 0 | 0 | 0 | 0          | 52.5  | -140 | 0     | 0.6  |                          |
| Euro IV            | All                                  | -1.49        | 0.0181  | 0         | 0 | 0 | 0 | 0          | 52.5  | -140 | 0     | 0.6  |                          |
| <i>HGV</i>         |                                      |              |         |           |   |   |   |            |       |      |       |      |                          |
| Pre-1988 models    | rigid                                | 1.61         | 0       | 0         | 0 | 0 | 0 | 0          | 26.2  | 686  | -2514 | 1.30 | 5 - 100                  |
|                    | artic                                | 0.93         | 0       | 0.000078  | 0 | 0 | 0 | 0          | 81.1  | 0    | -161  | 1.31 |                          |
| 1988 - 1993 models | rigid                                | 1.61         | 0       | 0         | 0 | 0 | 0 | 0          | 26.2  | 686  | -2514 | 1    |                          |
|                    | artic                                | 0.93         | 0       | 0.000078  | 0 | 0 | 0 | 0          | 81.1  | 0    | -161  | 1    |                          |
| Euro I             | rigid                                | 0.66         | 0       | 0.0000214 | 0 | 0 | 0 | 0          | 28.6  | 171  | -671  | 1    |                          |
|                    | artic                                | 1.84         | 0       | 0.00006   | 0 | 0 | 0 | 0          | 80.2  | 479  | -1882 | 1    |                          |
| Euro II            | rigid                                | 0.74         | 0       | 0         | 0 | 0 | 0 | 0          | 12    | 314  | -1150 | 1    |                          |
|                    | artic                                | 1.98         | 0       | 0         | 0 | 0 | 0 | 0          | 32.2  | 844  | -3092 | 1    |                          |
| Euro III           | rigid                                | 0.74         | 0       | 0         | 0 | 0 | 0 | 0          | 12    | 314  | -1150 | 0.7  |                          |
|                    | artic                                | 1.98         | 0       | 0         | 0 | 0 | 0 | 0          | 32.2  | 844  | -3092 | 0.7  |                          |
| Euro IV            | rigid                                | 0.74         | 0       | 0         | 0 | 0 | 0 | 0          | 12    | 314  | -1150 | 0.51 |                          |
|                    | artic                                | 1.98         | 0       | 0         | 0 | 0 | 0 | 0          | 32.2  | 844  | -3092 | 0.51 |                          |
| Euro IV+ (2008)    | rigid                                | 0.74         | 0       | 0         | 0 | 0 | 0 | 0          | 12    | 314  | -1150 | 0.51 |                          |
|                    | artic                                | 1.98         | 0       | 0         | 0 | 0 | 0 | 0          | 32.2  | 844  | -3092 | 0.51 |                          |
| <i>Buses</i>       |                                      |              |         |           |   |   |   |            |       |      |       |      |                          |
| Pre-1988 models    | All                                  | 0.28         | 0       | 0         | 0 | 0 | 0 | 0.00000294 | 137   | 0    | 0     | 2.25 | 5 - 60                   |
| 1988 - 1993 models | All                                  | 0.28         | 0       | 0         | 0 | 0 | 0 | 0.00000294 | 137   | 0    | 0     | 1    |                          |
| Euro I             | All                                  | 0.612        | 0       | 0.00002   | 0 | 0 | 0 | 0          | 26.7  | 160  | -627  | 1    |                          |
| Euro II            | All                                  | 0.691        | 0       | 0         | 0 | 0 | 0 | 0          | 11.2  | 294  | -1079 | 1    |                          |
| Euro III           | All                                  | 0.691        | 0       | 0         | 0 | 0 | 0 | 0          | 11.2  | 294  | -1079 | 0.7  |                          |
| Euro IV            | All                                  | 0.691        | 0       | 0         | 0 | 0 | 0 | 0          | 11.2  | 294  | -1079 | 0.51 |                          |
| Euro IV+ (2008)    | All                                  | 0.691        | 0       | 0         | 0 | 0 | 0 | 0          | 11.2  | 294  | -1079 | 0.51 |                          |

**Table B5 Emission Function Coefficients for Carbon Monoxide (continued)**

| Legislation class  | Engine size or vehicle configuration | Coefficients |        |         |   |   |   |   |       |       |   |   | Valid speed range (km/h) |         |
|--------------------|--------------------------------------|--------------|--------|---------|---|---|---|---|-------|-------|---|---|--------------------------|---------|
|                    |                                      | a            | b      | c       | d | e | f | g | h     | i     | j | x |                          |         |
| <i>Motorcycles</i> |                                      |              |        |         |   |   |   |   |       |       |   |   |                          |         |
| Pre-2000           | moped (2-stroke)                     | 6.48         | 0.404  | 0       | 0 | 0 | 0 | 0 | 0     | 0     | 0 | 0 | 1                        | 20 - 30 |
|                    | <250 cc 2-stroke                     | 20.7         | 0.0719 | 0       | 0 | 0 | 0 | 0 | -17.6 | 0     | 0 | 0 | 1                        | 5 - 130 |
|                    | <250 cc 4-stroke                     | 2.05         | 0      | 0.00285 | 0 | 0 | 0 | 0 | 770   | -2360 | 0 | 0 | 1                        |         |
|                    | 250-750 cc 4-stroke                  | 9.29         | 0      | 0.00113 | 0 | 0 | 0 | 0 | 490   | -1436 | 0 | 0 | 1                        |         |
|                    | >750 cc 4-stroke                     | 4.97         | 0      | 0.0015  | 0 | 0 | 0 | 0 | 414   | -1196 | 0 | 0 | 1                        |         |
| 97/24/EC           | moped (2-stroke)                     | 6.48         | 0.404  | 0       | 0 | 0 | 0 | 0 | 0     | 0     | 0 | 0 | 0.10                     | 20 - 30 |
|                    | <250 cc 2-stroke                     | 20.7         | 0.0719 | 0       | 0 | 0 | 0 | 0 | -17.6 | 0     | 0 | 0 | 0.52                     | 5 - 130 |
|                    | <250 cc 4-stroke                     | 2.05         | 0      | 0.00285 | 0 | 0 | 0 | 0 | 770   | -2360 | 0 | 0 | 0.29                     |         |
|                    | 250-750 cc 4-stroke                  | 9.29         | 0      | 0.00113 | 0 | 0 | 0 | 0 | 490   | -1436 | 0 | 0 | 0.31                     |         |
|                    | >750 cc 4-stroke                     | 4.97         | 0      | 0.0015  | 0 | 0 | 0 | 0 | 414   | -1196 | 0 | 0 | 0.43                     |         |

**Table B6 Emission Function Coefficients for Total Hydrocarbons**

| Legislation class | Engine size or vehicle configuration | Coefficients |         |         |   |   |   |         |       |       |     |      | Valid speed range (km/h) |
|-------------------|--------------------------------------|--------------|---------|---------|---|---|---|---------|-------|-------|-----|------|--------------------------|
|                   |                                      | a            | b       | c       | d | e | f | g       | h     | i     | j   | x    |                          |
| <i>Petrol car</i> |                                      |              |         |         |   |   |   |         |       |       |     |      |                          |
| Pre- ECE          | < 1.4 l                              | 1.85         | -0.0197 | 0       | 0 | 0 | 0 | 6.8e-07 | 18.5  | 0     | 0   | 1.58 | 5 - 130                  |
|                   | 1.4 - 2.0 l                          | 2.13         | -0.0317 | 0.00017 | 0 | 0 | 0 | 0       | 16.7  | 0     | 0   | 1.58 |                          |
|                   | > 2.0 l                              | 1.22         | -0.0108 | 0       | 0 | 0 | 0 | 3.4e-07 | 25.8  | 0     | 0   | 1.58 |                          |
| ECE 15.00         | < 1.4 l                              | 1.85         | -0.0197 | 0       | 0 | 0 | 0 | 6.8e-07 | 18.5  | 0     | 0   | 1.23 |                          |
|                   | 1.4 - 2.0 l                          | 2.13         | -0.0317 | 0.00017 | 0 | 0 | 0 | 0       | 16.7  | 0     | 0   | 1.23 |                          |
|                   | > 2.0 l                              | 1.22         | -0.0108 | 0       | 0 | 0 | 0 | 3.4e-07 | 25.8  | 0     | 0   | 1.23 |                          |
| ECE 15.01         | < 1.4 l                              | 1.85         | -0.0197 | 0       | 0 | 0 | 0 | 6.8e-07 | 18.5  | 0     | 0   | 1.23 |                          |
|                   | 1.4 - 2.0 l                          | 2.13         | -0.0317 | 0.00017 | 0 | 0 | 0 | 0       | 16.7  | 0     | 0   | 1.23 |                          |
|                   | > 2.0 l                              | 1.22         | -0.0108 | 0       | 0 | 0 | 0 | 3.4e-07 | 25.8  | 0     | 0   | 1.23 |                          |
| ECE 15.02         | < 1.4 l                              | 1.85         | -0.0197 | 0       | 0 | 0 | 0 | 6.8e-07 | 18.5  | 0     | 0   | 1.25 |                          |
|                   | 1.4 - 2.0 l                          | 2.13         | -0.0317 | 0.00017 | 0 | 0 | 0 | 0       | 16.7  | 0     | 0   | 1.25 |                          |
|                   | > 2.0 l                              | 1.22         | -0.0108 | 0       | 0 | 0 | 0 | 3.4e-07 | 25.8  | 0     | 0   | 1.25 |                          |
| ECE 15.03         | < 1.4 l                              | 1.85         | -0.0197 | 0       | 0 | 0 | 0 | 6.8e-07 | 18.5  | 0     | 0   | 1.25 |                          |
|                   | 1.4 - 2.0 l                          | 2.13         | -0.0317 | 0.00017 | 0 | 0 | 0 | 0       | 16.7  | 0     | 0   | 1.25 |                          |
|                   | > 2.0 l                              | 1.22         | -0.0108 | 0       | 0 | 0 | 0 | 3.4e-07 | 25.8  | 0     | 0   | 1.25 |                          |
| ECE 15.04         | < 1.4 l                              | 1.85         | -0.0197 | 0       | 0 | 0 | 0 | 6.8e-07 | 18.5  | 0     | 0   | 1    |                          |
|                   | 1.4 - 2.0 l                          | 2.13         | -0.0317 | 0.00017 | 0 | 0 | 0 | 0       | 16.7  | 0     | 0   | 1    |                          |
|                   | > 2.0 l                              | 1.22         | -0.0108 | 0       | 0 | 0 | 0 | 3.4e-07 | 25.8  | 0     | 0   | 1    |                          |
| Euro I            | < 1.4 l                              | -0.52        | 0.00492 | 0       | 0 | 0 | 0 | 0       | 18.7  | -92.3 | 186 | 1    |                          |
|                   | 1.4 - 2.0 l                          | 0.14         | -0.0054 | 4.7e-05 | 0 | 0 | 0 | 0       | 3.47  | 0     | 0   | 1    |                          |
|                   | > 2.0 l                              | -0.0487      | 0.00076 | 0       | 0 | 0 | 0 | 0       | 7.16  | 0     | -42 | 1    |                          |
| Euro II           | < 1.4 l                              | 0.185        | -0.0033 | 1.9e-05 | 0 | 0 | 0 | 0       | 0     | 0     | 0   | 1    |                          |
|                   | 1.4 - 2.0 l                          | 0.0501       | 0       | 0       | 0 | 0 | 0 | 0       | 0     | 12.1  | 0   | 1    |                          |
|                   | > 2.0 l                              | -0.0017      | -2e-05  | 0       | 0 | 0 | 0 | 0       | 1.2   | 0     | 0   | 1    |                          |
| Euro III          | < 1.4 l                              | 0.185        | -0.0033 | 1.9e-05 | 0 | 0 | 0 | 0       | 0     | 0     | 0   | 0.7  |                          |
|                   | 1.4 - 2.0 l                          | 0.0501       | 0       | 0       | 0 | 0 | 0 | 0       | 0     | 12.1  | 0   | 0.7  |                          |
|                   | > 2.0 l                              | -0.0017      | -2e-05  | 0       | 0 | 0 | 0 | 0       | 1.2   | 0     | 0   | 0.7  |                          |
| Euro IV           | < 1.4 l                              | 0.185        | -0.0033 | 1.9e-05 | 0 | 0 | 0 | 0       | 0     | 0     | 0   | 0.53 |                          |
|                   | 1.4 - 2.0 l                          | 0.0501       | 0       | 0       | 0 | 0 | 0 | 0       | 0     | 12.1  | 0   | 0.53 |                          |
|                   | > 2.0 l                              | -0.0017      | -2e-05  | 0       | 0 | 0 | 0 | 0       | 1.2   | 0     | 0   | 0.53 |                          |
| <i>Diesel car</i> |                                      |              |         |         |   |   |   |         |       |       |     |      |                          |
| Pre-Euro I        | < 2.0 l                              | 0.00641      | 0       | 0       | 0 | 0 | 0 | 0       | 6.23  | -3.88 | 0   | 1    | 5 - 130                  |
|                   | > 2.0 l                              | 0.104        | -0.0019 | 0.00001 | 0 | 0 | 0 | 0       | 4.12  | -8.01 | 0   | 1    |                          |
| Euro I            | < 2.0 l                              | 0.0157       | 0       | 0       | 0 | 0 | 0 | 0       | 2.64  | 0     | 0   | 1    |                          |
|                   | > 2.0 l                              | 0.139        | -0.0023 | 0       | 0 | 0 | 0 | 1.1e-07 | 0.663 | 0     | 0   | 1    |                          |
| Euro II           | < 2.0 l                              | 0.0784       | -0.0012 | 0       | 0 | 0 | 0 | 4.6e-08 | 1.04  | 0     | 0   | 1    |                          |
|                   | > 2.0 l                              | 0.0473       | -0.0003 | 0       | 0 | 0 | 0 | 0       | 2.06  | 0     | 0   | 1    |                          |
| Euro III          | < 2.0 l                              | 0.0784       | -0.0012 | 0       | 0 | 0 | 0 | 4.6e-08 | 1.04  | 0     | 0   | 0.7  |                          |
|                   | > 2.0 l                              | 0.0473       | -0.0003 | 0       | 0 | 0 | 0 | 0       | 2.06  | 0     | 0   | 0.7  |                          |
| Euro IV           | < 2.0 l                              | 0.0784       | -0.0012 | 0       | 0 | 0 | 0 | 4.6e-08 | 1.04  | 0     | 0   | 0.64 |                          |
|                   | > 2.0 l                              | 0.0473       | -0.0003 | 0       | 0 | 0 | 0 | 0       | 2.06  | 0     | 0   | 0.64 |                          |

**Table B6 Emission Function Coefficients for Total Hydrocarbons (continued)**

| Legislation class  | Engine size or vehicle configuration | Coefficients |          |         |   |   |   |         |        |       |        |      | Valid speed range (km/h) |
|--------------------|--------------------------------------|--------------|----------|---------|---|---|---|---------|--------|-------|--------|------|--------------------------|
|                    |                                      | a            | b        | c       | d | e | f | g       | h      | i     | j      | x    |                          |
| <b>Petrol LDV</b>  |                                      |              |          |         |   |   |   |         |        |       |        |      |                          |
| Pre-Euro I         | All                                  | 2.624        | -0.0477  | 0.00023 | 0 | 0 | 0 | 3.4e-07 | 18.44  | 8.1   | 0      | 1    | 5 – 130                  |
| Euro I             | All                                  | 0.0626       | 0        | 0       | 0 | 0 | 0 | 0       | 1.41   | 0     | 0      | 1    |                          |
| Euro II            | All                                  | 0.0501       | 0        | 0       | 0 | 0 | 0 | 0       | 0      | 12.1  | 0      | 1    |                          |
| Euro III           | All                                  | 0.0501       | 0        | 0       | 0 | 0 | 0 | 0       | 0      | 12.1  | 0      | 0.7  |                          |
| Euro IV            | All                                  | 0.0501       | 0        | 0       | 0 | 0 | 0 | 0       | 0      | 12.1  | 0      | 0.53 |                          |
| <b>Diesel LDV</b>  |                                      |              |          |         |   |   |   |         |        |       |        |      |                          |
| Pre-Euro I         | All                                  | 0.602        | -0.00878 | 1.9e-05 | 0 | 0 | 0 | 2.2e-07 | 0.0678 | 11.44 | -36.24 | 1    | 5 - 130                  |
| Euro I             | All                                  | 0.071        | 0        | 0       | 0 | 0 | 0 | 0       | 2.36   | 0     | 0      | 1    |                          |
| Euro II            | All                                  | 0.071        | 0        | 0       | 0 | 0 | 0 | 0       | 2.36   | 0     | 0      | 1    |                          |
| Euro III           | All                                  | 0.071        | 0        | 0       | 0 | 0 | 0 | 0       | 2.36   | 0     | 0      | 0.78 |                          |
| Euro IV            | All                                  | 0.071        | 0        | 0       | 0 | 0 | 0 | 0       | 2.36   | 0     | 0      | 0.41 |                          |
| <b>HGV</b>         |                                      |              |          |         |   |   |   |         |        |       |        |      |                          |
| Pre-1988 models    | rigid                                | 0.756        | 0        | 2.7e-05 | 0 | 0 | 0 | 0       | 33.3   | 381   | -1416  | 2.01 | 5 - 100                  |
|                    | artic                                | 0.259        | 0        | 0       | 0 | 0 | 0 | -6e-08  | 56.7   | -9.01 | 0      | 2.52 |                          |
| 1988 - 1993 models | rigid                                | 0.756        | 0        | 2.7e-05 | 0 | 0 | 0 | 0       | 33.3   | 381   | -1416  | 1    |                          |
|                    | artic                                | 0.259        | 0        | 0       | 0 | 0 | 0 | -6e-08  | 56.7   | -9.01 | 0      | 1    |                          |
| Euro I             | rigid                                | 0.284        | 1e-05    | 0       | 0 | 0 | 0 | 0       | 12.5   | 143   | -532   | 1    |                          |
|                    | artic                                | 0.736        | 2.6e-05  | 0       | 0 | 0 | 0 | 0       | 32.5   | 371   | -1379  | 1    |                          |
| Euro II            | rigid                                | 0.0366       | 0.002    | 0       | 0 | 0 | 0 | 0       | 16.8   | 0     | -118   | 1    |                          |
|                    | artic                                | 0.0984       | 0.0054   | 0       | 0 | 0 | 0 | 0       | 45.5   | 0     | -320   | 1    |                          |
| Euro III           | rigid                                | 0.0366       | 0.002    | 0       | 0 | 0 | 0 | 0       | 16.8   | 0     | -118   | 0.7  |                          |
|                    | artic                                | 0.0984       | 0.0054   | 0       | 0 | 0 | 0 | 0       | 45.5   | 0     | -320   | 0.7  |                          |
| Euro IV            | rigid                                | 0.0366       | 0.002    | 0       | 0 | 0 | 0 | 0       | 16.8   | 0     | -118   | 0.49 |                          |
|                    | artic                                | 0.0984       | 0.0054   | 0       | 0 | 0 | 0 | 0       | 45.5   | 0     | -320   | 0.49 |                          |
| Euro IV+ (2008)    | rigid                                | 0.0366       | 0.002    | 0       | 0 | 0 | 0 | 0       | 16.8   | 0     | -118   | 0.49 |                          |
|                    | artic                                | 0.0984       | 0.0054   | 0       | 0 | 0 | 0 | 0       | 45.5   | 0     | -320   | 0.49 |                          |
| <b>Buses</b>       |                                      |              |          |         |   |   |   |         |        |       |        |      |                          |
| Pre-1998 models    | All                                  | 0.448        | 0        | 0       | 0 | 0 | 0 | 0       | 0      | 430   | -1093  | 4.13 | 5 - 60                   |
| 1988 - 1993 models | All                                  | 0.448        | 0        | 0       | 0 | 0 | 0 | 0       | 0      | 430   | -1093  | 1    |                          |
| Euro I             | All                                  | 0.267        | 9.6e-06  | 0       | 0 | 0 | 0 | 0       | 11.8   | 135   | -501   | 1    |                          |
| Euro II            | All                                  | 0.0341       | 0.00187  | 0       | 0 | 0 | 0 | 0       | 15.8   | 0     | -111   | 1    |                          |
| Euro III           | All                                  | 0.0341       | 0.00187  | 0       | 0 | 0 | 0 | 0       | 15.8   | 0     | -111   | 0.7  |                          |
| Euro IV            | All                                  | 0.0341       | 0.00187  | 0       | 0 | 0 | 0 | 0       | 15.8   | 0     | -111   | 0.49 |                          |
| Euro IV+ (2008)    | All                                  | 0.0341       | 0.00187  | 0       | 0 | 0 | 0 | 0       | 15.8   | 0     | -111   | 0.49 |                          |

**Table B6 Emission Function Coefficients for Total Hydrocarbons (continued)**

| Legislation class  | Engine size or vehicle configuration | Coefficients |       |   |   |   |   |         |      |      |       |      | Valid speed range (km/h) |         |
|--------------------|--------------------------------------|--------------|-------|---|---|---|---|---------|------|------|-------|------|--------------------------|---------|
|                    |                                      | a            | b     | c | d | e | f | g       | h    | i    | j     | x    |                          |         |
| <i>Motorcycles</i> |                                      |              |       |   |   |   |   |         |      |      |       |      |                          |         |
| Pre-2000           | moped (2-stroke)                     | 3.81         | 0.198 | 0 | 0 | 0 | 0 | 0       | 0    | 0    | 0     | 0    | 1                        | 20 - 30 |
|                    | <250 cc 2-stroke                     | 5.78         | 0     | 0 | 0 | 0 | 0 | 7.7e-07 | 168  | -436 | 0     | 1    | 5 - 130                  |         |
|                    | <250 cc 4-stroke                     | 0.0844       | 0     | 0 | 0 | 0 | 0 | 6.8e-07 | 63.3 | 0    | -657  | 1    |                          |         |
|                    | 250-750 cc 4-stroke                  | 0.131        | 0     | 0 | 0 | 0 | 0 | 3.4e-07 | 55   | 0    | -517  | 1    |                          |         |
|                    | >750cc 4-stroke                      | 0.466        | 0     | 0 | 0 | 0 | 0 | 0       | 90.1 | 0    | -1064 | 1    |                          |         |
| 97/24/EC           | moped (2-stroke)                     | 3.81         | 0.198 | 0 | 0 | 0 | 0 | 0       | 0    | 0    | 0     | 0.22 | 20 - 30                  |         |
|                    | <250 cc 2-stroke                     | 5.78         | 0     | 0 | 0 | 0 | 0 | 7.7e-07 | 168  | -436 | 0     | 0.69 | 5 - 130                  |         |
|                    | <250 cc 4-stroke                     | 0.0844       | 0     | 0 | 0 | 0 | 0 | 6.8e-07 | 63.3 | 0    | -657  | 0.49 |                          |         |
|                    | 250-750 cc 4-stroke                  | 0.131        | 0     | 0 | 0 | 0 | 0 | 3.4e-07 | 55   | 0    | -517  | 0.55 |                          |         |
|                    | >750 cc 4-stroke                     | 0.466        | 0     | 0 | 0 | 0 | 0 | 0       | 90.1 | 0    | -1064 | 0.29 |                          |         |

**Table B7 Emission Function Coefficients for Total Oxides of Nitrogen**

| Legislation class | Engine size or vehicle configuration | Coefficients             |          |           |   |   |   |           |       |       |      |      | Valid speed range (km/h) |
|-------------------|--------------------------------------|--------------------------|----------|-----------|---|---|---|-----------|-------|-------|------|------|--------------------------|
|                   |                                      | a                        | b        | c         | d | e | f | g         | h     | i     | j    | x    |                          |
| <i>Petrol car</i> |                                      |                          |          |           |   |   |   |           |       |       |      |      |                          |
| Pre- ECE          | < 1.4 l                              | 1.173                    | 0.0225   | -0.00014  | 0 | 0 | 0 | 0         | 0     | 0     | 0    | 1    | 5 - 130                  |
|                   | 1.4 - 2.0 l                          | 1.36                     | 0.0217   | -0.00004  | 0 | 0 | 0 | 0         | 0     | 0     | 0    | 1    |                          |
|                   | > 2.0 l                              | 1.5                      | 0.03     | 0.0001    | 0 | 0 | 0 | 0         | 0     | 0     | 0    | 1    |                          |
| ECE 15.00         | < 1.4 l                              | 1.173                    | 0.0225   | -0.00014  | 0 | 0 | 0 | 0         | 0     | 0     | 0    | 1    |                          |
|                   | 1.4 - 2.0 l                          | 1.36                     | 0.0217   | -0.00004  | 0 | 0 | 0 | 0         | 0     | 0     | 0    | 1    |                          |
|                   | > 2.0 l                              | 1.5                      | 0.03     | 0.0001    | 0 | 0 | 0 | 0         | 0     | 0     | 0    | 1    |                          |
| ECE 15.01         | < 1.4 l                              | 1.173                    | 0.0225   | -0.00014  | 0 | 0 | 0 | 0         | 0     | 0     | 0    | 1    |                          |
|                   | 1.4 - 2.0 l                          | 1.36                     | 0.0217   | -0.00004  | 0 | 0 | 0 | 0         | 0     | 0     | 0    | 1    |                          |
|                   | > 2.0 l                              | 1.5                      | 0.03     | 0.0001    | 0 | 0 | 0 | 0         | 0     | 0     | 0    | 1    |                          |
| ECE 15.02         | < 1.4 l                              | 1.479                    | -0.0037  | 0.00018   | 0 | 0 | 0 | 0         | 0     | 0     | 0    | 1    |                          |
|                   | 1.4 - 2.0 l                          | 1.663                    | -0.0038  | 0.0002    | 0 | 0 | 0 | 0         | 0     | 0     | 0    | 1    |                          |
|                   | > 2.0 l                              | 1.87                     | -0.0039  | 0.00022   | 0 | 0 | 0 | 0         | 0     | 0     | 0    | 1    |                          |
| ECE 15.03         | < 1.4 l                              | 1.616                    | -0.0084  | 0.00025   | 0 | 0 | 0 | 0         | 0     | 0     | 0    | 1    |                          |
|                   | 1.4 - 2.0 l                          | E.F. = 1.29.exp(.0099*v) |          |           |   |   |   |           |       |       |      | 1    |                          |
|                   | > 2.0 l                              | 2.784                    | -0.0112  | 0.000294  | 0 | 0 | 0 | 0         | 0     | 0     | 0    | 1    |                          |
| ECE 15.04         | < 1.4 l                              | 1.12                     | 0.001    | 0.000145  | 0 | 0 | 0 | -1.57e-07 | 0     | 0     | 0    | 1    |                          |
|                   | 1.4 - 2.0 l                          | 1.35                     | 0.00433  | 0.000137  | 0 | 0 | 0 | 0         | 0     | 0     | 0    | 1    |                          |
|                   | > 2.0 l                              | 1.91                     | 0        | 0.000089  | 0 | 0 | 0 | 5.95e-07  | 0     | 0     | 0    | 1    |                          |
| Euro I            | < 1.4 l                              | 0.161                    | 0        | 0         | 0 | 0 | 0 | 4.11e-07  | 2.82  | 0     | 0    | 1    |                          |
|                   | 1.4 - 2.0 l                          | -0.375                   | 0.008    | 0         | 0 | 0 | 0 | 0         | 12.5  | -51.5 | 81.1 | 1    |                          |
|                   | > 2.0 l                              | 0.389                    | 0        | -0.000092 | 0 | 0 | 0 | 9.2e-07   | 0     | 0     | 70   | 1    |                          |
| Euro II           | < 1.4 l                              | 0.25                     | -0.00283 | 0         | 0 | 0 | 0 | 1.72e-07  | 0.182 | 0     | 0    | 1    |                          |
|                   | 1.4 - 2.0 l                          | 0.302                    | 0        | 0         | 0 | 0 | 0 | 1.99e-07  | 0     | 0     | 0    | 1    |                          |
|                   | > 2.0 l                              | 0.265                    | -0.0028  | 0         | 0 | 0 | 0 | 3.53e-07  | 0     | 0     | 0    | 1    |                          |
| Euro III          | < 1.4 l                              | 0.25                     | -0.00283 | 0         | 0 | 0 | 0 | 1.72e-07  | 0.182 | 0     | 0    | 0.6  |                          |
|                   | 1.4 - 2.0 l                          | 0.302                    |          | 0         | 0 | 0 | 0 | 1.99e-07  | 0     | 0     | 0    | 0.6  |                          |
|                   | > 2.0 l                              | 0.265                    | -0.0028  | 0         | 0 | 0 | 0 | 3.53e-07  | 0     | 0     | 0    | 0.6  |                          |
| Euro IV           | < 1.4 l                              | 0.25                     | -0.00283 | 0         | 0 | 0 | 0 | 1.72e-07  | 0.182 | 0     | 0    | 0.32 |                          |
|                   | 1.4 - 2.0 l                          | 0.302                    |          | 0         | 0 | 0 | 0 | 1.99e-07  | 0     | 0     | 0    | 0.32 |                          |
|                   | > 2.0 l                              | 0.265                    | -0.0028  | 0         | 0 | 0 | 0 | 3.53e-07  | 0     | 0     | 0    | 0.32 |                          |
| <i>Diesel car</i> |                                      |                          |          |           |   |   |   |           |       |       |      |      |                          |
| Pre-Euro I        | < 2.0 l                              | 0.88                     | -0.0115  | 0.000086  | 0 | 0 | 0 | 0         | 1.67  | 0     | 0    | 1    | 5 - 130                  |
|                   | > 2.0 l                              | 0.638                    | 0        | 0         | 0 | 0 | 0 | 2.04e-07  | 6.02  | -10.6 | 0    | 1    |                          |
| Euro I            | < 2.0 l                              | 0.514                    | 0        | -0.000064 | 0 | 0 | 0 | 7.07e-07  | 0     | 119   | -408 | 1    |                          |
|                   | > 2.0 l                              | -0.378                   | 0        | 0         | 0 | 0 | 0 | 4.98e-07  | 47    | -327  | 790  | 1    |                          |
| Euro II           | < 2.0 l                              | 0.844                    | -0.00884 | 0         | 0 | 0 | 0 | 7.08e-07  | 0     | 0     | 0    | 1    |                          |
|                   | > 2.0 l                              | 0.358                    | 0        | 0         | 0 | 0 | 0 | 2.51e-07  | 11.5  | 0     | 0    | 1    |                          |
| Euro III          | < 2.0 l                              | 0.844                    | -0.00884 | 0         | 0 | 0 | 0 | 7.08e-07  | 0     | 0     | 0    | 1    |                          |
|                   | > 2.0 l                              | 0.358                    | 0        | 0         | 0 | 0 | 0 | 2.51e-07  | 11.5  | 0     | 0    | 1    |                          |
| Euro IV           | < 2.0 l                              | 0.844                    | -0.00884 | 0         | 0 | 0 | 0 | 7.08e-07  | 0     | 0     | 0    | 0.5  |                          |
|                   | > 2.0 l                              | 0.358                    | 0        | 0         | 0 | 0 | 0 | 2.51e-07  | 11.5  | 0     | 0    | 0.5  |                          |

**Table B7 Emission Function Coefficients for Total Oxides of Nitrogen (continued)**

| Legislation class  | Engine size or vehicle configuration | Coefficients |          |           |         |           |   |          |        |       |        |      | Valid speed range (km/h) |         |
|--------------------|--------------------------------------|--------------|----------|-----------|---------|-----------|---|----------|--------|-------|--------|------|--------------------------|---------|
|                    |                                      | a            | b        | c         | d       | e         | f | g        | h      | i     | j      | x    |                          |         |
| <b>Petrol LGV</b>  |                                      |              |          |           |         |           |   |          |        |       |        |      |                          |         |
| Pre-Euro I         | All                                  | 1.596        | -0.00672 | 0.000124  | 0       | 0         | 0 | 0        | 0      | 0     | 0      | 0    | 1                        | 5 - 130 |
| Euro I             | All                                  | 0.414        | 0        | -0.000054 | 0       | 0         | 0 | 5.77e-07 | 0      | 0     | 0      | 0    | 1                        |         |
| Euro II            | All                                  | 0.302        | 0        | 0         | 0       | 0         | 0 | 1.99e-07 | 0      | 0     | 0      | 0    | 1                        |         |
| Euro III           | All                                  | 0.302        | 0        | 0         | 0       | 0         | 0 | 1.99e-07 | 0      | 0     | 0      | 0    | 0.6                      |         |
| Euro IV            | All                                  | 0.302        | 0        | 0         | 0       | 0         | 0 | 1.99e-07 | 0      | 0     | 0      | 0    | 0.33                     |         |
| <b>Diesel LGV</b>  |                                      |              |          |           |         |           |   |          |        |       |        |      |                          |         |
| Pre-Euro I         | All                                  | 0.9552       | 0        | -3.16e-05 | 0       | 0         | 0 | 6.24e-07 | 15.692 | 0     | -27.52 | 1    | 5 - 130                  |         |
| Euro I             | All                                  | 1.31         | 0        | -0.00025  | 0       | 0         | 0 | 2.32e-06 | 0      | 0     | 0      | 0    |                          | 1       |
| Euro II            | All                                  | 1.31         | 0        | -0.00025  | 0       | 0         | 0 | 2.32e-06 | 0      | 0     | 0      | 0    |                          | 0.95    |
| Euro III           | All                                  | 1.31         | 0        | -0.00025  | 0       | 0         | 0 | 2.32e-06 | 0      | 0     | 0      | 0    |                          | 0.71    |
| Euro IV            | All                                  | 1.31         | 0        | -0.00025  | 0       | 0         | 0 | 2.32e-06 | 0      | 0     | 0      | 0    |                          | 0.37    |
| <b>HGV</b>         |                                      |              |          |           |         |           |   |          |        |       |        |      |                          |         |
| Pre-1988 models    | rigid                                | 13.5         | 0        | 0         | 0       | 0         | 0 | 0        | 0      | 0     | 0      | 0    | 1                        | 5 - 100 |
|                    | artic                                | 20.7         | 0        | 0         | 0       | 0         | 0 | 0        | 0      | 0     | 0      | 0    | 1                        |         |
| 1988 - 1993 models | rigid                                | 4.34         | -0.0464  | 0         | 0       | 0         | 0 | 5.64e-06 | 133    | -107  | 0      | 1    |                          |         |
|                    | artic                                | 6.86         | 0        | 0         | 0       | 0         | 0 | 0        | 441    | -1118 | 639    | 1    |                          |         |
| Euro I             | rigid                                | 4.4          | 0        | 0         | 0       | 0         | 0 | 1.87e-06 | 126    | 0     | -805   | 1    |                          |         |
|                    | artic                                | 11.7         | 0        | 0         | 0       | 0         | 0 | 4.99e-06 | 334    | 0     | -2141  | 1    |                          |         |
| Euro II            | rigid                                | 4.66         | -0.0303  | 0.000356  | 0       | 0         | 0 | 0.00e+00 | 106    | -178  | 0      | 1    |                          |         |
|                    | artic                                | 10           | -0.0651  | 0.000764  | 0       | 0         | 0 | 0.00e+00 | 227    | -381  | 0      | 1    |                          |         |
| Euro III           | rigid                                | 4.66         | -0.0303  | 0.000356  | 0       | 0         | 0 | 0.00e+00 | 106    | -178  | 0      | 0.69 |                          |         |
|                    | artic                                | 10           | -0.0651  | 0.000764  | 0       | 0         | 0 | 0.00e+00 | 227    | -381  | 0      | 0.69 |                          |         |
| Euro IV            | rigid                                | 4.66         | -0.0303  | 0.000356  | 0       | 0         | 0 | 0.00e+00 | 106    | -178  | 0      | 0.49 |                          |         |
|                    | artic                                | 10           | -0.0651  | 0.000764  | 0       | 0         | 0 | 0.00e+00 | 227    | -381  | 0      | 0.49 |                          |         |
| Euro IV+ (2008)    | rigid                                | 4.66         | -0.0303  | 0.000356  | 0       | 0         | 0 | 0.00e+00 | 106    | -178  | 0      | 0.28 |                          |         |
|                    | artic                                | 10           | -0.0651  | 0.000764  | 0       | 0         | 0 | 0.00e+00 | 227    | -381  | 0      | 0.28 |                          |         |
| <b>Buses</b>       |                                      |              |          |           |         |           |   |          |        |       |        |      |                          |         |
| Pre-1988 models    | 0                                    | 0            | 0        | 0         | 23.9196 | -0.128837 | 0 | 0        | 0      | 0     | 0      | 0    | 1                        | 5 - 60  |
| 1988 - 1993 models | 0                                    | 17.1         | -0.323   | 2.21e-03  | 0       | 0         | 0 | 0        | 0      | 277   | 0      | 1    |                          |         |
| Euro I             | 0                                    | 3.96         | 0        | 0         | 0       | 0         | 0 | 1.69e-06 | 113    | 0     | -725   | 1    |                          |         |
| Euro II            | 0                                    | 4.46         | -0.0291  | 0.000341  | 0       | 0         | 0 | 0        | 101    | -170  | 0      | 1    |                          |         |
| Euro III           | 0                                    | 4.46         | -0.0291  | 0.000341  | 0       | 0         | 0 | 0        | 101    | -170  | 0      | 0.69 |                          |         |
| Euro IV            | 0                                    | 4.46         | -0.0291  | 0.000341  | 0       | 0         | 0 | 0        | 101    | -170  | 0      | 0.49 |                          |         |
| Euro IV+ (2008)    | 0                                    | 4.46         | -0.0291  | 0.000341  | 0       | 0         | 0 | 0        | 101    | -170  | 0      | 0.28 |                          |         |



**Table B7 Emission Function Coefficients for Total Oxides of Nitrogen (continued)**

| Legislation class  | Engine size or vehicle configuration | Coefficients |         |          |   |   |   |           |       |   |   |      | Valid speed range (km/h) |
|--------------------|--------------------------------------|--------------|---------|----------|---|---|---|-----------|-------|---|---|------|--------------------------|
|                    |                                      | a            | b       | c        | d | e | f | g         | h     | i | j | x    |                          |
| <i>Motorcycles</i> |                                      |              |         |          |   |   |   |           |       |   |   |      |                          |
| Pre-2000           | moped (2-stroke)                     | 0.03         | 0       | 0        | 0 | 0 | 0 | 0         | 0     | 0 | 0 | 1    | 20 - 30                  |
|                    | <250 cc 2-stroke                     | 0.0151       | 0       | 9.24e-06 | 0 | 0 | 0 | 0         | 0     | 0 | 0 | 1    | 5 - 130                  |
|                    | <250 cc 4-stroke                     | 0.055        | 0.00226 | 0        | 0 | 0 | 0 | -5.89e-08 | 0     | 0 | 0 | 1    |                          |
|                    | 250-750 cc 4-stroke                  | 0.096        | 0       | 0        | 0 | 0 | 0 | 2.58e-07  | 0     | 0 | 0 | 1    |                          |
|                    | >750 cc 4-stroke                     | 0.16         | 0       | 0.000022 | 0 | 0 | 0 | 0         | 0.738 | 0 | 0 | 1    |                          |
| 97/24/EC           | moped (2-stroke)                     | 0.03         | 0       | 0        | 0 | 0 | 0 | 0         | 0     | 0 | 0 | 0.33 | 20 - 30                  |
|                    | <250 cc 2-stroke                     | 0.0151       | 0       | 9.24e-06 | 0 | 0 | 0 | 0         | 0     | 0 | 0 | 0.78 | 5 - 130                  |
|                    | <250 cc 4-stroke                     | 0.055        | 0.00226 | 0        | 0 | 0 | 0 | -5.89e-08 | 0     | 0 | 0 | 1.43 |                          |
|                    | 250-750 cc 4-stroke                  | 0.096        | 0       | 0        | 0 | 0 | 0 | 2.58e-07  | 0     | 0 | 0 | 1.37 |                          |
|                    | >750 cc 4-stroke                     | 0.16         | 0       | 0.000022 | 0 | 0 | 0 | 0         | 0.738 | 0 | 0 | 1.26 |                          |

**Table B8 Emission Function Coefficients for Particulate Matter**

| Legislation class | Engine size or vehicle configuration | Coefficients |           |           |   |   |   |          |         |       |      |      | Valid speed range (km/h) |
|-------------------|--------------------------------------|--------------|-----------|-----------|---|---|---|----------|---------|-------|------|------|--------------------------|
|                   |                                      | a            | b         | c         | d | e | f | g        | h       | i     | j    | x    |                          |
| <i>Petrol car</i> |                                      |              |           |           |   |   |   |          |         |       |      |      |                          |
| Pre-Euro I        | < 1.4 l                              | 0.0324       | -0.00040  | 0         | 0 | 0 | 0 | 2.21e-08 | 0.377   | 0     | 0    | 1    | 5 - 130                  |
|                   | 1.4 - 2.0 l                          | 0.0227       | -0.00028  | 0         | 0 | 0 | 0 | 1.48e-08 | 0.427   | 0     | 0    | 1    |                          |
|                   | > 2.0 l                              | 0.0232       | -0.00058  | 4.29e-06  | 0 | 0 | 0 | 0        | 0.582   | 0     | 0    | 1    |                          |
| Euro I            | < 1.4 l                              | 0.00244      | 0         | -8.53e-07 | 0 | 0 | 0 | 8.72e-09 | 0.00795 | 0     | 0    | 1    |                          |
|                   | 1.4 - 2.0 l                          | 0.00307      | 0         | 0         | 0 | 0 | 0 | 8.35e-09 | 0       | 0     | 0    | 1    |                          |
|                   | > 2.0 l                              | 0.00672      | 0         | -1.54e-06 | 0 | 0 | 0 | 1.52e-08 | 0       | 0     | 0    | 1    |                          |
| Euro II           | < 1.4 l                              | 0.00356      | -0.00013  | 1.38e-06  | 0 | 0 | 0 | 0        | 0       | 0     | 0    | 1    |                          |
|                   | 1.4 - 2.0 l                          | 0.0024       | -0.000046 | 0         | 0 | 0 | 0 | 5.59e-09 | 0       | 0     | 0    | 1    |                          |
|                   | > 2.0 l                              | 0.0024       | 0         | -1.64e-06 | 0 | 0 | 0 | 1.73e-08 | 0       | 0     | 0    | 1    |                          |
| Euro III          | < 1.4 l                              | 0.00356      | -0.00013  | 1.38e-06  | 0 | 0 | 0 | 0        | 0       | 0     | 0    | 1    |                          |
|                   | 1.4 - 2.0 l                          | 0.0024       | -0.000046 | 0         | 0 | 0 | 0 | 5.59e-09 | 0       | 0     | 0    | 1    |                          |
|                   | > 2.0 l                              | 0.0024       | 0         | -1.64e-06 | 0 | 0 | 0 | 1.73e-08 | 0       | 0     | 0    | 1    |                          |
| Euro IV           | < 1.4 l                              | 0.00356      | -0.00013  | 1.38e-06  | 0 | 0 | 0 | 0        | 0       | 0     | 0    | 1    |                          |
|                   | 1.4 - 2.0 l                          | 0.0024       | -0.000046 | 0         | 0 | 0 | 0 | 5.59e-09 | 0       | 0     | 0    | 1    |                          |
|                   | > 2.0 l                              | 0.0024       | 0         | -1.64e-06 | 0 | 0 | 0 | 1.73e-08 | 0       | 0     | 0    | 1    |                          |
| <i>Diesel car</i> |                                      |              |           |           |   |   |   |          |         |       |      |      |                          |
| Pre-Euro I        | < 2.0 l                              | 0.131        | 0         | -0.000014 | 0 | 0 | 0 | 1.54e-07 | 2.16    | 0     | 0    | 1    | 5 - 130                  |
|                   | > 2.0 l                              | 0.282        | -0.00399  | 0.000026  | 0 | 0 | 0 | 2.53e-08 | 1.32    | 0     | 0    | 1    |                          |
| Euro I            | < 2.0 l                              | 0.189        | -0.00176  | 0         | 0 | 0 | 0 | 8.93e-08 | -3.84   | 60.4  | -191 | 1    |                          |
|                   | > 2.0 l                              | 0.0857       | -0.000901 | 0         | 0 | 0 | 0 | 7.56e-08 | 1.02    | 0     | -4.5 | 1    |                          |
| Euro II           | < 2.0 l                              | 0.0722       | 0         | -0.000018 | 0 | 0 | 0 | 1.51e-07 | 0       | 0     | 0    | 1    |                          |
|                   | > 2.0 l                              | 0.113        | 0         | -2.24e-05 | 0 | 0 | 0 | 2e-07    | 0       | 0     | 30.4 | 1    |                          |
| Euro III          | < 2.0 l                              | 0.0722       | 0         | -0.000018 | 0 | 0 | 0 | 1.51e-07 | 0       | 0     | 0    | 0.7  |                          |
|                   | > 2.0 l                              | 0.113        | 0         | -2.24e-05 | 0 | 0 | 0 | 2e-07    | 0       | 0     | 30.4 | 0.7  |                          |
| Euro IV           | < 2.0 l                              | 0.0722       | 0         | -0.000018 | 0 | 0 | 0 | 1.51e-07 | 0       | 0     | 0    | 0.35 |                          |
|                   | > 2.0 l                              | 0.113        | 0         | -2.24e-05 | 0 | 0 | 0 | 2e-07    | 0       | 0     | 30.4 | 0.35 |                          |
| <i>Petrol LGV</i> |                                      |              |           |           |   |   |   |          |         |       |      |      |                          |
| Pre-Euro I        | All                                  | 0.03472      | 0         | -1.46e-05 | 0 | 0 | 0 | 1.56e-07 | 0.39335 | 0     | 0    | 1    |                          |
| Euro I            | All                                  | 0.00307      | 0         | 0         | 0 | 0 | 0 | 8.35e-09 | 0       | 0     | 0    | 1    |                          |
| Euro II           | All                                  | 0.0024       | -0.000046 | 0         | 0 | 0 | 0 | 5.59e-09 | 0       | 0     | 0    | 1    |                          |
| Euro III          | All                                  | 0.0024       | -0.000046 | 0         | 0 | 0 | 0 | 5.59e-09 | 0       | 0     | 0    | 1    |                          |
| Euro IV           | All                                  | 0.0024       | -0.000046 | 0         | 0 | 0 | 0 | 5.59e-09 | 0       | 0     | 0    | 1    |                          |
| <i>Diesel LGV</i> |                                      |              |           |           |   |   |   |          |         |       |      |      |                          |
| Pre-Euro I        | All                                  | 0.553        | -0.006604 | 0.00002   | 0 | 0 | 0 | 2.54e-07 | -0.526  | 13.36 | 0    | 1    | 5 - 130                  |
| Euro I            | All                                  | 0.127        | 0         | -0.000038 | 0 | 0 | 0 | 4.15e-07 | 0       | 0     | 0    | 1    |                          |
| Euro II           | All                                  | 0.127        | 0         | -0.000038 | 0 | 0 | 0 | 4.15e-07 | 0       | 0     | 0    | 1    |                          |
| Euro III          | All                                  | 0.127        | 0         | -0.000038 | 0 | 0 | 0 | 4.15e-07 | 0       | 0     | 0    | 0.8  |                          |
| Euro IV           | All                                  | 0.127        | 0         | -0.000038 | 0 | 0 | 0 | 4.15e-07 | 0       | 0     | 0    | 0.49 |                          |

**Table B8 Emission Function Coefficients for Particulate Matter (continued)**

| Legislation class  | Engine size or vehicle configuration | Coefficients |          |          |   |   |   |          |      |       |      |      | Valid speed range (km/h) |
|--------------------|--------------------------------------|--------------|----------|----------|---|---|---|----------|------|-------|------|------|--------------------------|
|                    |                                      | a            | b        | c        | d | e | f | g        | h    | i     | j    | x    |                          |
| <b>HGVS</b>        |                                      |              |          |          |   |   |   |          |      |       |      |      |                          |
| Pre-1988 models    | rigid                                | 0.174        | 0        | 0        | 0 | 0 | 0 | 1e-07    | 14.4 | 0     | 0    | 2.09 | 5 - 100                  |
|                    | artic                                | 0.283        | 0        | 0        | 0 | 0 | 0 | 0        | 20.9 | -12.8 | 0    | 1.14 |                          |
| 1988 - 1993 models | rigid                                | 0.174        | 0        | 0        | 0 | 0 | 0 | 1.00e-07 | 14.4 | 0     | 0    | 1    |                          |
|                    | artic                                | 0.283        | 0        | 0        | 0 | 0 | 0 | 0        | 20.9 | -12.8 | 0    | 1    |                          |
| Euro I             | rigid                                | 0.0896       | 0        | 0        | 0 | 0 | 0 | 5.16e-08 | 7.43 | 0     | 0    | 1    |                          |
|                    | artic                                | 0.236        | 0        | 0        | 0 | 0 | 0 | 1.36e-07 | 19.5 | 0     | 0    | 1    |                          |
| Euro II            | rigid                                | 0.111        | -0.00145 | 1.26e-05 | 0 | 0 | 0 | 0        | 4.05 | -6.7  | 0    | 1    |                          |
|                    | artic                                | 0.288        | -0.00379 | 0.000033 | 0 | 0 | 0 | 0        | 10.6 | -17.5 | 0    | 1    |                          |
| Euro III           | rigid                                | 0.111        | -0.00145 | 1.26e-05 | 0 | 0 | 0 | 0        | 4.05 | -6.7  | 0    | 0.72 |                          |
|                    | artic                                | 0.288        | -0.00379 | 0.000033 | 0 | 0 | 0 | 0        | 10.6 | -17.5 | 0    | 0.72 |                          |
| Euro IV            | rigid                                | 0.111        | -0.00145 | 1.26e-05 | 0 | 0 | 0 | 0        | 4.05 | -6.7  | 0    | 0.15 |                          |
|                    | artic                                | 0.288        | -0.00379 | 0.000033 | 0 | 0 | 0 | 0        | 10.6 | -17.5 | 0    | 0.15 |                          |
| Euro IV+ (2008)    | rigid                                | 0.111        | -0.00145 | 1.26e-05 | 0 | 0 | 0 | 0        | 4.05 | -6.7  | 0    | 0.15 |                          |
|                    | artic                                | 0.288        | -0.00379 | 0.000033 | 0 | 0 | 0 | 0        | 10.6 | -17.5 | 0    | 0.15 |                          |
| <b>Buses</b>       |                                      |              |          |          |   |   |   |          |      |       |      |      |                          |
| Pre-1988 models    | All                                  | 0.128        | 0        | 0        | 0 | 0 | 0 | 0        | 14.4 | 0     | 0    | 2.31 | 5 - 60                   |
| 1988 - 1993 models | All                                  | 0.128        | 0        | 0        | 0 | 0 | 0 | 0        | 14.4 | 0     | 0    | 1    |                          |
| Euro I             | All                                  | 0.0843       | 0        | 0        | 0 | 0 | 0 | 4.85e-08 | 6.98 | 0     | 0    | 1    |                          |
| Euro II            | All                                  | 0.104        | -0.00137 | 0.000012 | 0 | 0 | 0 | 0        | 3.81 | -6.3  | 0    | 1    |                          |
| Euro III           | All                                  | 0.104        | -0.00137 | 0.000012 | 0 | 0 | 0 | 0        | 3.81 | -6.3  | 0    | 0.72 |                          |
| Euro IV            | All                                  | 0.104        | -0.00137 | 0.000012 | 0 | 0 | 0 | 0        | 3.81 | -6.3  | 0    | 0.15 |                          |
| Euro IV+ (2008)    | All                                  | 0.104        | -0.00137 | 0.000012 | 0 | 0 | 0 | 3.81     | -6.3 | 0     | 0.15 |      |                          |
| <b>Motorcycles</b> |                                      |              |          |          |   |   |   |          |      |       |      |      |                          |
| Pre-2000           | moped (2-stroke)                     | 0.04         | 0        | 0        | 0 | 0 | 0 | 0        | 0    | 0     | 0    | 1    | 20 - 30                  |
|                    | <250 cc 2-stroke                     | 0.04         | 0        | 0        | 0 | 0 | 0 | 0        | 0    | 0     | 0    | 1    | 5 - 130                  |
|                    | <250cc 4-stroke                      | 0.12         | 0        | 0        | 0 | 0 | 0 | 0        | 0    | 0     | 0    | 1    |                          |
|                    | 250-750 cc 4-stroke                  | 0.12         | 0        | 0        | 0 | 0 | 0 | 0        | 0    | 0     | 0    | 1    |                          |
|                    | >750 cc 4-stroke                     | 0.12         | 0        | 0        | 0 | 0 | 0 | 0        | 0    | 0     | 0    | 1    |                          |
| 97/24/EC           | moped (2-stroke)                     | 0.04         | 0        | 0        | 0 | 0 | 0 | 0        | 0    | 0     | 0    | 1    | 20 - 30                  |
|                    | <250 cc 2-stroke                     | 0.04         | 0        | 0        | 0 | 0 | 0 | 0        | 0    | 0     | 0    | 1    | 5 - 130                  |
|                    | <250 cc 4-stroke                     | 0.12         | 0        | 0        | 0 | 0 | 0 | 0        | 0    | 0     | 0    | 1    |                          |
|                    | 250-750 cc 4-stroke                  | 0.12         | 0        | 0        | 0 | 0 | 0 | 0        | 0    | 0     | 0    | 1    |                          |
|                    | >750 cc 4-stroke                     | 0.12         | 0        | 0        | 0 | 0 | 0 | 0        | 0    | 0     | 0    | 1    |                          |

Table B9 Emission Function Coefficients for Benzene

| Legislation class | Engine size or vehicle configuration | Coefficients |           |          |   |   |   |          |       |       |     |        | Valid speed range (km/h) |
|-------------------|--------------------------------------|--------------|-----------|----------|---|---|---|----------|-------|-------|-----|--------|--------------------------|
|                   |                                      | a            | b         | c        | d | e | f | g        | h     | i     | j   | x      |                          |
| <i>Petrol car</i> |                                      |              |           |          |   |   |   |          |       |       |     |        |                          |
| Pre-ECE           | < 1.4 l                              | 1.85         | -0.0197   | 0        | 0 | 0 | 0 | 6.77e-07 | 18.5  | 0     | 0   | 0.1026 | 5 - 130                  |
|                   | 1.4 - 2.0 l                          | 2.13         | -0.0317   | 0.000169 | 0 | 0 | 0 | 0        | 16.7  | 0     | 0   | 0.1026 |                          |
|                   | > 2.0 l                              | 1.22         | -0.0108   | 0        | 0 | 0 | 0 | 3.42e-07 | 25.8  | 0     | 0   | 0.1026 |                          |
| ECE 15.00         | < 1.4 l                              | 1.85         | -0.0197   | 0        | 0 | 0 | 0 | 6.77e-07 | 18.5  | 0     | 0   | 0.0804 |                          |
|                   | 1.4 - 2.0 l                          | 2.13         | -0.0317   | 0.000169 | 0 | 0 | 0 | 0        | 16.7  | 0     | 0   | 0.0804 |                          |
|                   | > 2.0 l                              | 1.22         | -0.0108   | 0        | 0 | 0 | 0 | 3.42e-07 | 25.8  | 0     | 0   | 0.0804 |                          |
| ECE 15.01         | < 1.4 l                              | 1.85         | -0.0197   | 0        | 0 | 0 | 0 | 6.77e-07 | 18.5  | 0     | 0   | 0.0804 |                          |
|                   | 1.4 - 2.0 l                          | 2.13         | -0.0317   | 0.000169 | 0 | 0 | 0 | 0        | 16.7  | 0     | 0   | 0.0804 |                          |
|                   | > 2.0 l                              | 1.22         | -0.0108   | 0        | 0 | 0 | 0 | 3.42e-07 | 25.8  | 0     | 0   | 0.0804 |                          |
| ECE 15.02         | < 1.4 l                              | 1.85         | -0.0197   | 0        | 0 | 0 | 0 | 6.77e-07 | 18.5  | 0     | 0   | 0.0811 |                          |
|                   | 1.4 - 2.0 l                          | 2.13         | -0.0317   | 0.000169 | 0 | 0 | 0 | 0        | 16.7  | 0     | 0   | 0.0811 |                          |
|                   | > 2.0 l                              | 1.22         | -0.0108   | 0        | 0 | 0 | 0 | 3.42e-07 | 25.8  | 0     | 0   | 0.0811 |                          |
| ECE 15.03         | < 1.4 l                              | 1.85         | -0.0197   | 0        | 0 | 0 | 0 | 6.77e-07 | 18.5  | 0     | 0   | 0.0811 |                          |
|                   | 1.4 - 2.0 l                          | 2.13         | -0.0317   | 0.000169 | 0 | 0 | 0 | 0        | 16.7  | 0     | 0   | 0.0811 |                          |
|                   | > 2.0 l                              | 1.22         | -0.0108   | 0        | 0 | 0 | 0 | 3.42e-07 | 25.8  | 0     | 0   | 0.0811 |                          |
| ECE 15.04         | < 1.4 l                              | 1.85         | -0.0197   | 0        | 0 | 0 | 0 | 6.77e-07 | 18.5  | 0     | 0   | 0.0651 |                          |
|                   | 1.4 - 2.0 l                          | 2.13         | -0.0317   | 0.000169 | 0 | 0 | 0 | 0        | 16.7  | 0     | 0   | 0.0651 |                          |
|                   | > 2.0 l                              | 1.22         | -0.0108   | 0        | 0 | 0 | 0 | 3.42e-07 | 25.8  | 0     | 0   | 0.0651 |                          |
| Euro I            | < 1.4 l                              | -0.52        | 0.00492   | 0        | 0 | 0 | 0 | 0        | 18.7  | -92.3 | 186 | 0.0401 |                          |
|                   | 1.4 - 2.0 l                          | 0.14         | -0.00541  | 0.000047 | 0 | 0 | 0 | 0        | 3.47  | 0     | 0   | 0.0401 |                          |
|                   | > 2.0 l                              | -0.0487      | 0.000762  | 0        | 0 | 0 | 0 | 0        | 7.16  | 0     | -42 | 0.0401 |                          |
| Euro II           | < 1.4 l                              | 0.185        | -0.00331  | 1.89e-05 | 0 | 0 | 0 | 0        | 0     | 0     | 0   | 0.0401 |                          |
|                   | 1.4 - 2.0 l                          | 0.0501       | 0         | 0        | 0 | 0 | 0 | 0        | 0     | 12.1  | 0   | 0.0401 |                          |
|                   | > 2.0 l                              | -0.00167     | -1.57e-05 | 0        | 0 | 0 | 0 | 0        | 1.2   | 0     | 0   | 0.0401 |                          |
| Euro III          | < 1.4 l                              | 0.185        | -0.00331  | 1.89e-05 | 0 | 0 | 0 | 0        | 0     | 0     | 0   | 0.0281 |                          |
|                   | 1.4 - 2.0 l                          | 0.0501       | 0         | 0        | 0 | 0 | 0 | 0        | 0     | 12.1  | 0   | 0.0281 |                          |
|                   | > 2.0 l                              | -0.00167     | -1.57e-05 | 0        | 0 | 0 | 0 | 0        | 1.2   | 0     | 0   | 0.0281 |                          |
| Euro IV           | < 1.4 l                              | 0.185        | -0.00331  | 1.89e-05 | 0 | 0 | 0 | 0        | 0     | 0     | 0   | 0.0213 |                          |
|                   | 1.4 - 2.0 l                          | 0.0501       | 0         | 0        | 0 | 0 | 0 | 0        | 0     | 12.1  | 0   | 0.0213 |                          |
|                   | > 2.0 l                              | -0.00167     | -1.57e-05 | 0        | 0 | 0 | 0 | 0        | 1.2   | 0     | 0   | 0.0213 |                          |
| <i>Diesel car</i> |                                      |              |           |          |   |   |   |          |       |       |     |        |                          |
| Pre-Euro I        | < 2.0 l                              | 0.00641      | 0         | 0        | 0 | 0 | 0 | 0        | 6.23  | -3.88 | 0   | 0.0171 | 5 - 130                  |
|                   | > 2.0 l                              | 0.104        | -0.00193  | 0.00001  | 0 | 0 | 0 | 0        | 4.12  | -8.01 | 0   | 0.0171 |                          |
| Euro I            | < 2.0 l                              | 0.0157       | 0         | 0        | 0 | 0 | 0 | 0        | 2.64  | 0     | 0   | 0.0171 |                          |
|                   | > 2.0 l                              | 0.139        | -0.00234  | 0        | 0 | 0 | 0 | 1.1e-07  | 0.663 | 0     | 0   | 0.0171 |                          |
| Euro II           | < 2.0 l                              | 0.0784       | -0.00115  | 0        | 0 | 0 | 0 | 4.62e-08 | 1.04  | 0     | 0   | 0.0171 |                          |
|                   | > 2.0 l                              | 0.0473       | -0.00027  | 0        | 0 | 0 | 0 | 0        | 2.06  | 0     | 0   | 0.0171 |                          |
| Euro III          | < 2.0 l                              | 0.0784       | -0.00115  | 0        | 0 | 0 | 0 | 4.62e-08 | 1.04  | 0     | 0   | 0.0119 |                          |
|                   | > 2.0 l                              | 0.0473       | -0.00027  | 0        | 0 | 0 | 0 | 0        | 2.06  | 0     | 0   | 0.0119 |                          |
| Euro IV           | < 2.0 l                              | 0.0784       | -0.00115  | 0        | 0 | 0 | 0 | 4.62e-08 | 1.04  | 0     | 0   | 0.0109 |                          |
|                   | > 2.0 l                              | 0.0473       | -0.00027  | 0        | 0 | 0 | 0 | 0        | 2.06  | 0     | 0   | 0.0109 |                          |

Table B9 Emission Function Coefficients for Benzene (continued)

| Legislation class  | Engine size or vehicle configuration | Coefficients |          |          |   |   |   |           |        |       |        |        | Valid speed range (km/h) |
|--------------------|--------------------------------------|--------------|----------|----------|---|---|---|-----------|--------|-------|--------|--------|--------------------------|
|                    |                                      | a            | b        | c        | d | e | f | g         | h      | i     | j      | x      |                          |
| <b>Petrol LGV</b>  |                                      |              |          |          |   |   |   |           |        |       |        |        |                          |
| Pre-Euro I         | All                                  | 2.624        | -0.0477  | 0.000234 | 0 | 0 | 0 | 3.42e-07  | 18.44  | 8.1   | 0      | 0.0639 | 5 - 130                  |
| Euro I             | All                                  | 0.0626       | 0        | 0        | 0 | 0 | 0 | 0         | 1.41   | 0     | 0      | 0.0380 |                          |
| Euro II            | All                                  | 0.0501       | 0        | 0        | 0 | 0 | 0 | 0         | 0      | 12.1  | 0      | 0.0380 |                          |
| Euro III           | All                                  | 0.0501       | 0        | 0        | 0 | 0 | 0 | 0         | 0      | 12.1  | 0      | 0.0266 |                          |
| Euro IV            | All                                  | 0.0501       | 0        | 0        | 0 | 0 | 0 | 0         | 0      | 12.1  | 0      | 0.0202 |                          |
| <b>Diesel LGV</b>  |                                      |              |          |          |   |   |   |           |        |       |        |        |                          |
| Pre-Euro I         | All                                  | 0.602        | -0.00878 | 1.88e-05 | 0 | 0 | 0 | 2.18e-07  | 0.0678 | 11.44 | -36.24 | 0.0193 |                          |
| Euro I             | All                                  | 0.071        | 0        | 0        | 0 | 0 | 0 | 0         | 2.36   | 0     | 0      | 0.0193 |                          |
| Euro II            | All                                  | 0.071        | 0        | 0        | 0 | 0 | 0 | 0         | 2.36   | 0     | 0      | 0.0193 |                          |
| Euro III           | All                                  | 0.071        | 0        | 0        | 0 | 0 | 0 | 0         | 2.36   | 0     | 0      | 0.0150 |                          |
| Euro IV            | All                                  | 0.071        | 0        | 0        | 0 | 0 | 0 | 0         | 2.36   | 0     | 0      | 0.0079 |                          |
| <b>HGV</b>         |                                      |              |          |          |   |   |   |           |        |       |        |        |                          |
| Pre-1988 models    | rigid                                | 0.756        | 0        | 0.000027 | 0 | 0 | 0 | 0         | 33.3   | 381   | -1416  | 0.0014 | 5 - 100                  |
|                    | artic                                | 0.259        | 0        | 0        | 0 | 0 | 0 | -5.57e-08 | 56.7   | -9.01 | 0      | 0.0016 |                          |
| 1988 - 1993 models | rigid                                | 0.756        | 0        | 0.000027 | 0 | 0 | 0 | 0.00e+00  | 33.3   | 381   | -1416  | 0.0007 |                          |
|                    | artic                                | 0.259        | 0        | 0        | 0 | 0 | 0 | -5.57e-08 | 56.7   | -9.01 | 0      | 0.0006 |                          |
| Euro I             | rigid                                | 0.284        | 1.02e-05 | 0        | 0 | 0 | 0 | 0         | 12.5   | 143   | -532   | 0.0007 |                          |
|                    | artic                                | 0.736        | 0.000026 | 0        | 0 | 0 | 0 | 0         | 32.5   | 371   | -1379  | 0.0006 |                          |
| Euro II            | rigid                                | 0.0366       | 0.002    | 0        | 0 | 0 | 0 | 0         | 16.8   | 0     | -118   | 0.0007 |                          |
|                    | artic                                | 0.0984       | 0.0054   | 0        | 0 | 0 | 0 | 0         | 45.5   | 0     | -320   | 0.0006 |                          |
| Euro III           | rigid                                | 0.0366       | 0.002    | 0        | 0 | 0 | 0 | 0         | 16.8   | 0     | -118   | 0.0005 |                          |
|                    | artic                                | 0.0984       | 0.0054   | 0        | 0 | 0 | 0 | 0         | 45.5   | 0     | -320   | 0.0004 |                          |
| Euro IV            | rigid                                | 0.0366       | 0.002    | 0        | 0 | 0 | 0 | 0         | 16.8   | 0     | -118   | 0.0003 |                          |
|                    | artic                                | 0.0984       | 0.0054   | 0        | 0 | 0 | 0 | 0         | 45.5   | 0     | -320   | 0.0003 |                          |
| Euro IV+(2008)     | rigid                                | 0.0366       | 0.002    | 0        | 0 | 0 | 0 | 0         | 16.8   | 0     | -118   | 0.0003 |                          |
|                    | artic                                | 0.0984       | 0.0054   | 0        | 0 | 0 | 0 | 0         | 45.5   | 0     | -320   | 0.0003 |                          |
| <b>Buses</b>       |                                      |              |          |          |   |   |   |           |        |       |        |        |                          |
| Pre-1988 models    | All                                  | 0.448        | 0        | 0        | 0 | 0 | 0 | 0         | 0      | 430   | -1093  | 0.0026 | 5 - 60                   |
| 1988 - 1993 models | All                                  | 0.448        | 0        | 0        | 0 | 0 | 0 | 0         | 0      | 430   | -1093  | 0.0006 |                          |
| Euro I             | All                                  | 0.267        | 9.58e-06 | 0        | 0 | 0 | 0 | 0         | 11.8   | 135   | -501   | 0.0006 |                          |
| Euro II            | All                                  | 0.0341       | 0.00187  | 0        | 0 | 0 | 0 | 0         | 15.8   | 0     | -111   | 0.0006 |                          |
| Euro III           | All                                  | 0.0341       | 0.00187  | 0        | 0 | 0 | 0 | 0         | 15.8   | 0     | -111   | 0.0004 |                          |
| Euro IV            | All                                  | 0.0341       | 0.00187  | 0        | 0 | 0 | 0 | 0         | 15.8   | 0     | -111   | 0.0003 |                          |
| Euro IV+(2008)     | All                                  | 0.0341       | 0.00187  | 0        | 0 | 0 | 0 | 0         | 15.8   | 0     | -111   | 0.0003 |                          |

Table B9 Emission Function Coefficients for Benzene (continued)

| Legislation class  | Engine size or vehicle configuration | Coefficients |       |   |   |   |   |          |      |      |       |        | Valid speed range (km/h) |
|--------------------|--------------------------------------|--------------|-------|---|---|---|---|----------|------|------|-------|--------|--------------------------|
|                    |                                      | a            | b     | c | d | e | f | g        | h    | i    | j     | x      |                          |
| <i>Motorcycles</i> |                                      |              |       |   |   |   |   |          |      |      |       |        |                          |
| Pre-2000           | moped (2-stroke)                     | 3.81         | 0.198 | 0 | 0 | 0 | 0 | 0        | 0    | 0    | 0     | 0.0673 | 20 - 30                  |
|                    | <250 cc 2-stroke                     | 5.78         | 0     | 0 | 0 | 0 | 0 | 7.69e-07 | 168  | -436 | 0     | 0.0673 | 5 - 130                  |
|                    | <250 cc 4-stroke                     | 0.0844       | 0     | 0 | 0 | 0 | 0 | 6.75e-07 | 63.3 | 0    | -657  | 0.0673 |                          |
|                    | 250-750 cc 4-stroke                  | 0.131        | 0     | 0 | 0 | 0 | 0 | 3.37e-07 | 55   | 0    | -517  | 0.0673 |                          |
|                    | >750 cc 4-stroke                     | 0.466        | 0     | 0 | 0 | 0 | 0 | 0        | 90.1 | 0    | -1064 | 0.0673 |                          |
| 97/24/EC           | moped (2-stroke)                     | 3.81         | 0.198 | 0 | 0 | 0 | 0 | 0        | 0    | 0    | 0     | 0.0148 | 20 - 30                  |
|                    | <250 cc 2-stroke                     | 5.78         | 0     | 0 | 0 | 0 | 0 | 7.69e-07 | 168  | -436 | 0     | 0.0466 | 5 - 130                  |
|                    | <250 cc 4-stroke                     | 0.0844       | 0     | 0 | 0 | 0 | 0 | 6.75e-07 | 63.3 | 0    | -657  | 0.0328 |                          |
|                    | 250-750 cc 4-stroke                  | 0.131        | 0     | 0 | 0 | 0 | 0 | 3.37e-07 | 55   | 0    | -517  | 0.0370 |                          |
|                    | >750 cc 4-stroke                     | 0.466        | 0     | 0 | 0 | 0 | 0 | 0        | 90.1 | 0    | -1064 | 0.0199 |                          |

**Table B10 Emission Function Coefficients for 1,3-Butadiene**

| Legislation class | Engine size or vehicle configuration | Coefficients |           |          |   |   |   |          |       |       |     |        | Valid speed range (km/h) |
|-------------------|--------------------------------------|--------------|-----------|----------|---|---|---|----------|-------|-------|-----|--------|--------------------------|
|                   |                                      | a            | b         | c        | d | e | f | g        | h     | i     | j   | x      |                          |
| <i>Petrol car</i> |                                      |              |           |          |   |   |   |          |       |       |     |        |                          |
| Pre-ECE           | < 1.4 l                              | 1.85         | -0.0197   | 0        | 0 | 0 | 0 | 6.77e-07 | 18.5  | 0     | 0   | 0.0213 | 5 - 130                  |
|                   | 1.4 - 2.0 l                          | 2.13         | -0.0317   | 0.000169 | 0 | 0 | 0 | 0        | 16.7  | 0     | 0   | 0.0213 |                          |
|                   | > 2.0 l                              | 1.22         | -0.0108   | 0        | 0 | 0 | 0 | 3.42e-07 | 25.8  | 0     | 0   | 0.0213 |                          |
| ECE 15.00         | < 1.4 l                              | 1.85         | -0.0197   | 0        | 0 | 0 | 0 | 6.77e-07 | 18.5  | 0     | 0   | 0.0167 |                          |
|                   | 1.4 - 2.0 l                          | 2.13         | -0.0317   | 0.000169 | 0 | 0 | 0 | 0        | 16.7  | 0     | 0   | 0.0167 |                          |
|                   | > 2.0 l                              | 1.22         | -0.0108   | 0        | 0 | 0 | 0 | 3.42e-07 | 25.8  | 0     | 0   | 0.0167 |                          |
| ECE 15.01         | < 1.4 l                              | 1.85         | -0.0197   | 0        | 0 | 0 | 0 | 6.77e-07 | 18.5  | 0     | 0   | 0.0167 |                          |
|                   | 1.4 - 2.0 l                          | 2.13         | -0.0317   | 0.000169 | 0 | 0 | 0 | 0        | 16.7  | 0     | 0   | 0.0167 |                          |
|                   | > 2.0 l                              | 1.22         | -0.0108   | 0        | 0 | 0 | 0 | 3.42e-07 | 25.8  | 0     | 0   | 0.0167 |                          |
| ECE 15.02         | < 1.4 l                              | 1.85         | -0.0197   | 0        | 0 | 0 | 0 | 6.77e-07 | 18.5  | 0     | 0   | 0.0169 |                          |
|                   | 1.4 - 2.0 l                          | 2.13         | -0.0317   | 0.000169 | 0 | 0 | 0 | 0        | 16.7  | 0     | 0   | 0.0169 |                          |
|                   | > 2.0 l                              | 1.22         | -0.0108   | 0        | 0 | 0 | 0 | 3.42e-07 | 25.8  | 0     | 0   | 0.0169 |                          |
| ECE 15.03         | < 1.4 l                              | 1.85         | -0.0197   | 0        | 0 | 0 | 0 | 6.77e-07 | 18.5  | 0     | 0   | 0.0169 |                          |
|                   | 1.4 - 2.0 l                          | 2.13         | -0.0317   | 0.000169 | 0 | 0 | 0 | 0        | 16.7  | 0     | 0   | 0.0169 |                          |
|                   | > 2.0 l                              | 1.22         | -0.0108   | 0        | 0 | 0 | 0 | 3.42e-07 | 25.8  | 0     | 0   | 0.0169 |                          |
| ECE 15.04         | < 1.4 l                              | 1.85         | -0.0197   | 0        | 0 | 0 | 0 | 6.77e-07 | 18.5  | 0     | 0   | 0.0135 |                          |
|                   | 1.4 - 2.0 l                          | 2.13         | -0.0317   | 0.000169 | 0 | 0 | 0 | 0        | 16.7  | 0     | 0   | 0.0135 |                          |
|                   | > 2.0 l                              | 1.22         | -0.0108   | 0        | 0 | 0 | 0 | 3.42e-07 | 25.8  | 0     | 0   | 0.0135 |                          |
| Euro I            | < 1.4 l                              | -0.52        | 0.00492   | 0        | 0 | 0 | 0 | 0        | 18.7  | -92.3 | 186 | 0.0065 |                          |
|                   | 1.4 - 2.0 l                          | 0.14         | -0.00541  | 0.000047 | 0 | 0 | 0 | 0        | 3.47  | 0     | 0   | 0.0065 |                          |
|                   | > 2.0 l                              | -0.0487      | 0.000762  | 0        | 0 | 0 | 0 | 0        | 7.16  | 0     | -42 | 0.0065 |                          |
| Euro II           | < 1.4 l                              | 0.185        | -0.00331  | 1.89e-05 | 0 | 0 | 0 | 0        | 0     | 0     | 0   | 0.0065 |                          |
|                   | 1.4 - 2.0 l                          | 0.0501       | 0         | 0        | 0 | 0 | 0 | 0        | 0     | 12.1  | 0   | 0.0065 |                          |
|                   | > 2.0 l                              | -0.00167     | -1.57e-05 | 0        | 0 | 0 | 0 | 0        | 1.2   | 0     | 0   | 0.0065 |                          |
| Euro III          | < 1.4 l                              | 0.185        | -0.00331  | 1.89e-05 | 0 | 0 | 0 | 0        | 0     | 0     | 0   | 0.0046 |                          |
|                   | 1.4 - 2.0 l                          | 0.0501       | 0         | 0        | 0 | 0 | 0 | 0        | 0     | 12.1  | 0   | 0.0046 |                          |
|                   | > 2.0 l                              | -0.00167     | -1.57e-05 | 0        | 0 | 0 | 0 | 0        | 1.2   | 0     | 0   | 0.0046 |                          |
| Euro IV           | < 1.4 l                              | 0.185        | -0.00331  | 1.89e-05 | 0 | 0 | 0 | 0        | 0     | 0     | 0   | 0.0035 |                          |
|                   | 1.4 - 2.0 l                          | 0.0501       | 0         | 0        | 0 | 0 | 0 | 0        | 0     | 12.1  | 0   | 0.0035 |                          |
|                   | > 2.0 l                              | -0.00167     | -1.57e-05 | 0        | 0 | 0 | 0 | 0        | 1.2   | 0     | 0   | 0.0035 |                          |
| <i>Diesel car</i> |                                      |              |           |          |   |   |   |          |       |       |     |        |                          |
| Pre-Euro I        | < 2.0 l                              | 0.00641      | 0         | 0        | 0 | 0 | 0 | 0        | 6.23  | -3.88 | 0   | 0.0084 | 5 - 130                  |
|                   | > 2.0 l                              | 0.104        | -0.00193  | 0.00001  | 0 | 0 | 0 | 0        | 4.12  | -8.01 | 0   | 0.0084 |                          |
| Euro I            | < 2.0 l                              | 0.0157       | 0         | 0        | 0 | 0 | 0 | 0        | 2.64  | 0     | 0   | 0.0084 |                          |
|                   | > 2.0 l                              | 0.139        | -0.00234  | 0        | 0 | 0 | 0 | 1.1e-07  | 0.663 | 0     | 0   | 0.0084 |                          |
| Euro II           | < 2.0 l                              | 0.0784       | -0.00115  | 0        | 0 | 0 | 0 | 4.62e-08 | 1.04  | 0     | 0   | 0.0084 |                          |
|                   | > 2.0 l                              | 0.0473       | -0.00027  | 0        | 0 | 0 | 0 | 0        | 2.06  | 0     | 0   | 0.0084 |                          |
| Euro III          | < 2.0 l                              | 0.0784       | -0.00115  | 0        | 0 | 0 | 0 | 4.62e-08 | 1.04  | 0     | 0   | 0.0058 |                          |
|                   | > 2.0 l                              | 0.0473       | -0.00027  | 0        | 0 | 0 | 0 | 0        | 2.06  | 0     | 0   | 0.0058 |                          |
| Euro IV           | < 2.0 l                              | 0.0784       | -0.00115  | 0        | 0 | 0 | 0 | 4.62e-08 | 1.04  | 0     | 0   | 0.0053 |                          |
|                   | > 2.0 l                              | 0.0473       | -0.00027  | 0        | 0 | 0 | 0 | 0        | 2.06  | 0     | 0   | 0.0053 |                          |

**Table B10 Emission Function Coefficients for 1,3-Butadiene (continued)**

| Legislation class  | Engine size or vehicle configuration | Coefficients |          |          |   |   |   |           |        |       |        |        | Valid speed range (km/h) |
|--------------------|--------------------------------------|--------------|----------|----------|---|---|---|-----------|--------|-------|--------|--------|--------------------------|
|                    |                                      | a            | b        | c        | d | e | f | g         | h      | i     | j      | x      |                          |
| <b>Petrol LGV</b>  |                                      |              |          |          |   |   |   |           |        |       |        |        |                          |
| Pre-Euro I         | All                                  | 2.624        | -0.0477  | 0.000234 | 0 | 0 | 0 | 3.42e-07  | 18.44  | 8.1   | 0      | 0.0133 | 5 - 130                  |
| Euro I             | All                                  | 0.0626       | 0        | 0        | 0 | 0 | 0 | 0         | 1.41   | 0     | 0      | 0.0062 |                          |
| Euro II            | All                                  | 0.0501       | 0        | 0        | 0 | 0 | 0 | 0         | 0      | 12.1  | 0      | 0.0062 |                          |
| Euro III           | All                                  | 0.0501       | 0        | 0        | 0 | 0 | 0 | 0         | 0      | 12.1  | 0      | 0.0043 |                          |
| Euro IV            | All                                  | 0.0501       | 0        | 0        | 0 | 0 | 0 | 0         | 0      | 12.1  | 0      | 0.0033 |                          |
| <b>Diesel LGV</b>  |                                      |              |          |          |   |   |   |           |        |       |        |        |                          |
| Pre-Euro I         | All                                  | 0.602        | -0.00878 | 1.88e-05 | 0 | 0 | 0 | 2.18e-07  | 0.0678 | 11.44 | -36.24 | 0.0094 | 5 - 130                  |
| Euro I             | All                                  | 0.071        | 0        | 0        | 0 | 0 | 0 | 0         | 2.36   | 0     | 0      | 0.0094 |                          |
| Euro II            | All                                  | 0.071        | 0        | 0        | 0 | 0 | 0 | 0         | 2.36   | 0     | 0      | 0.0094 |                          |
| Euro III           | All                                  | 0.071        | 0        | 0        | 0 | 0 | 0 | 0         | 2.36   | 0     | 0      | 0.0074 |                          |
| Euro IV            | All                                  | 0.071        | 0        | 0        | 0 | 0 | 0 | 0         | 2.36   | 0     | 0      | 0.0039 |                          |
| <b>HGV</b>         |                                      |              |          |          |   |   |   |           |        |       |        |        |                          |
| Pre-1988 models    | rigid                                | 0.756        | 0        | 0.000027 | 0 | 0 | 0 | 0         | 33.3   | 381   | -1416  | 0.0637 | 5 - 100                  |
|                    | artic                                | 0.259        | 0        | 0        | 0 | 0 | 0 | -5.57e-08 | 56.7   | -9.01 | 0      | 0.0761 |                          |
| 1988 - 1993 models | rigid                                | 0.756        | 0        | 0.000027 | 0 | 0 | 0 | 0.00e+00  | 33.3   | 381   | -1416  | 0.0317 |                          |
|                    | artic                                | 0.259        | 0        | 0        | 0 | 0 | 0 | -5.57e-08 | 56.7   | -9.01 | 0      | 0.0302 |                          |
| Euro I             | rigid                                | 0.284        | 1.02e-05 | 0        | 0 | 0 | 0 | 0         | 12.5   | 143   | -532   | 0.0317 |                          |
|                    | artic                                | 0.736        | 0.000026 | 0        | 0 | 0 | 0 | 0         | 32.5   | 371   | -1379  | 0.0302 |                          |
| Euro II            | rigid                                | 0.0366       | 0.002    | 0        | 0 | 0 | 0 | 0         | 16.8   | 0     | -118   | 0.0317 |                          |
|                    | artic                                | 0.0984       | 0.0054   | 0        | 0 | 0 | 0 | 0         | 45.5   | 0     | -320   | 0.0302 |                          |
| Euro III           | rigid                                | 0.0366       | 0.002    | 0        | 0 | 0 | 0 | 0         | 16.8   | 0     | -118   | 0.0222 |                          |
|                    | artic                                | 0.0984       | 0.0054   | 0        | 0 | 0 | 0 | 0         | 45.5   | 0     | -320   | 0.0212 |                          |
| Euro IV            | rigid                                | 0.0366       | 0.002    | 0        | 0 | 0 | 0 | 0         | 16.8   | 0     | -118   | 0.0155 |                          |
|                    | artic                                | 0.0984       | 0.0054   | 0        | 0 | 0 | 0 | 0         | 45.5   | 0     | -320   | 0.0148 |                          |
| Euro IV+ (2008)    | rigid                                | 0.0366       | 0.002    | 0        | 0 | 0 | 0 | 0         | 16.8   | 0     | -118   | 0.0155 |                          |
|                    | artic                                | 0.0984       | 0.0054   | 0        | 0 | 0 | 0 | 0         | 45.5   | 0     | -320   | 0.0148 |                          |
| <b>Buses</b>       |                                      |              |          |          |   |   |   |           |        |       |        |        |                          |
| Pre-1988 models    | All                                  | 0.448        | 0        | 0        | 0 | 0 | 0 | 0         | 0      | 430   | -1093  | 0.1209 | 5 - 60                   |
| 1988 - 1993 models | All                                  | 0.448        | 0        | 0        | 0 | 0 | 0 | 0         | 0      | 430   | -1093  | 0.0293 |                          |
| Euro I             | All                                  | 0.267        | 9.58e-06 | 0        | 0 | 0 | 0 | 0         | 11.8   | 135   | -501   | 0.0293 |                          |
| Euro II            | All                                  | 0.0341       | 0.00187  | 0        | 0 | 0 | 0 | 0         | 15.8   | 0     | -111   | 0.0293 |                          |
| Euro III           | All                                  | 0.0341       | 0.00187  | 0        | 0 | 0 | 0 | 0         | 15.8   | 0     | -111   | 0.0205 |                          |
| Euro IV            | All                                  | 0.0341       | 0.00187  | 0        | 0 | 0 | 0 | 0         | 15.8   | 0     | -111   | 0.0143 |                          |
| Euro IV+ (2008)    | All                                  | 0.0341       | 0.00187  | 0        | 0 | 0 | 0 | 0         | 15.8   | 0     | -111   | 0.0143 |                          |



**Table B10 Emission Function Coefficients for 1,3-Butadiene (continued)**

| Legislation class  | Engine size or vehicle configuration | Coefficients |       |   |   |   |   |          |      |      |       |        | Valid speed range (km/h) |
|--------------------|--------------------------------------|--------------|-------|---|---|---|---|----------|------|------|-------|--------|--------------------------|
|                    |                                      | a            | b     | c | d | e | f | g        | h    | i    | j     | x      |                          |
| <i>Motorcycles</i> |                                      |              |       |   |   |   |   |          |      |      |       |        |                          |
| Pre-2000           | moped (2-stroke)                     | 3.81         | 0.198 | 0 | 0 | 0 | 0 | 0        | 0    | 0    | 0     | 0.0140 | 20 - 30                  |
|                    | <250 cc 2-stroke                     | 5.78         | 0     | 0 | 0 | 0 | 0 | 7.69e-07 | 168  | -436 | 0     | 0.0140 | 5 - 130                  |
|                    | <250 cc 4-stroke                     | 0.0844       | 0     | 0 | 0 | 0 | 0 | 6.75e-07 | 63.3 | 0    | -657  | 0.0140 |                          |
|                    | 250-750 cc 4-stroke                  | 0.131        | 0     | 0 | 0 | 0 | 0 | 3.37e-07 | 55   | 0    | -517  | 0.0140 |                          |
|                    | >750 cc 4-stroke                     | 0.466        | 0     | 0 | 0 | 0 | 0 | 0        | 90.1 | 0    | -1064 | 0.0140 |                          |
| 97/24/EC           | moped (2-stroke)                     | 3.81         | 0.198 | 0 | 0 | 0 | 0 | 0        | 0    | 0    | 0     | 0.0031 | 20 - 30                  |
|                    | <250 cc 2-stroke                     | 5.78         | 0     | 0 | 0 | 0 | 0 | 7.69e-07 | 168  | -436 | 0     | 0.0097 | 5 - 130                  |
|                    | <250 cc 4-stroke                     | 0.0844       | 0     | 0 | 0 | 0 | 0 | 6.75e-07 | 63.3 | 0    | -657  | 0.0068 |                          |
|                    | 250-750 cc 4-stroke                  | 0.131        | 0     | 0 | 0 | 0 | 0 | 3.37e-07 | 55   | 0    | -517  | 0.0077 |                          |
|                    | >750 cc 4-stroke                     | 0.466        | 0     | 0 | 0 | 0 | 0 | 0        | 90.1 | 0    | -1064 | 0.0041 |                          |

B3.4 For carbon, the regional impact assessment is based upon the information presented in Web-TAG. It should be noted that in this context 'carbon' relates to the carbon bound in the emitted pollutants (carbon dioxide, carbon monoxide, hydrocarbons and particulate matter).

B3.5 Functions are given in Web-TAG to enable fuel consumption (in litres per km) to be calculated as a function of average speed for seven vehicle categories: petrol car, diesel car, petrol LGV, diesel LGV, OGV, OGV2 and PSV. Fuel consumption is estimated using a function of the form:

$$L = a + b.v + c.v^2 + d.v^3$$

Where:

$L$  = consumption, expressed in litres per kilometre.

$v$  = average link speed in kilometres per hour.

$a, b, c, d$  = parameters defined for each vehicle category.

B3.6 The parameters needed to calculate the fuel consumption are given in the Web-TAG unit 3.5.6. The parameters for the baseline reference year (as well as years prior to 2002) are given in Table B11. For cars and LGVs the equations are valid for a speed range of 10-130 km/h whereas for OGV1, 2 and PSV it is only valid for 10-100 km/h.

**Table B11 Fuel Consumption Coefficients (Reference Year 2002)**

| Vehicle category | Parameters   |               |              |               |
|------------------|--------------|---------------|--------------|---------------|
|                  | <i>a</i>     | <i>b</i>      | <i>c</i>     | <i>d</i>      |
| Petrol car       | 0.1880476408 | -0.0043794655 | 0.0000506795 | -0.0000001691 |
| Diesel car       | 0.1408661301 | -0.0028522230 | 0.0000286706 | -0.0000000693 |
| Petrol LGV       | 0.2524614774 | -0.0048699922 | 0.0000442438 | -0.0000000753 |
| Diesel LGV       | 0.1863759267 | -0.0026804914 | 0.0000117153 | 0.0000000823  |
| OGV1             | 0.7683375152 | -0.0225730318 | 0.0003176580 | -0.0000013544 |
| OGV2             | 1.0244315577 | -0.0302181229 | 0.0004428547 | -0.0000020059 |
| PSV              | 0.6346686739 | -0.0189897027 | 0.0002743130 | -0.0000012161 |

B3.7 Fuel consumption changes with improvements in vehicle efficiency. Vehicle efficiency assumptions are also given in Web-TAG, and these are shown in Table B12. These figures show changes in fuel consumption

and therefore negative figures indicate an improvement in vehicle efficiency. It is assumed that there are no changes between 1996 and 2002, and that there are no further changes beyond 2020.

**Table B12 Assumed Vehicle Fuel Efficiency Improvements**

| Vehicle category | 2002-2003<br>(actual)<br>(%) | 2003-2004<br>(actual)<br>(%) | 2004-2005<br>(%) | 2005-2010<br>(% pa) | 2010-2015<br>(% pa) | 2015-2020<br>(% pa) |
|------------------|------------------------------|------------------------------|------------------|---------------------|---------------------|---------------------|
| Petrol car       | -0.74                        | -0.75                        | -0.76            | -0.85               | -1.35               | -1.48               |
| Diesel car       | -1.18                        | -1.19                        | -1.21            | -1.22               | -1.35               | -1.24               |
| Petrol LGV       | -1.22                        | -1.56                        | -1.11            | -1.33               | 0                   | 0                   |
| Diesel LGV       | 0.97                         | -1.40                        | -1.78            | -1.49               | 0                   | 0                   |
| OGV1             | 0.46                         | 0                            | 0                | -1.23               | 0                   | 0                   |
| OGV2             | -0.17                        | 0                            | 0                | -1.23               | 0                   | 0                   |
| PSV              | 0                            | 0                            | 0                | 0                   | 0                   | 0                   |

B3.8 Once fuel consumption has been estimated, this can be converted into carbon emissions by multiplying by the grams of carbon estimated to be released from burning one litre of petrol or diesel. This is calculated by multiplying carbon content (i.e. the grams of carbon per gram of fuel by the density of the fuel (i.e. grams per litre):

$$C_y = L_y \times k_y$$

Where:

$C_y$  = carbon emission in year 'y' in grams.

$L_y$  = fuel consumption in year 'y'.

$k_y$  = carbon emission per litre of fuel burnt (in  $\text{g}_{\text{carbon}}$  per litre) in year y.

B3.9 Table B13 shows the estimated grams of carbon released from burning a litre of fuel. For 2005, 2006 and 2007 (and earlier years), the figures for conventional petrol and diesel fuel are assumed to be constant. The values prior to 2005 are assumed to be those for 2005. From 2008 to 2020, the figures change to reflect the introduction of biofuels.

**Table B13 Carbon Emission Per Litre of Fuel Burnt ( $k$ )**

| Year       | Emissions from petrol/bioethanol blend ( $\text{g}_{\text{carbon}} \text{ litre}^{-1}$ ) | Emissions from diesel/biodiesel blend ( $\text{g}_{\text{carbon}} \text{ litre}^{-1}$ ) |
|------------|--|---|
| 2005/06/07 | 627.57   | 717.15  |
| 2008       | 618.94   | 707.29  |
| 2009       | 614.23   | 701.91  |
| 2010       | 609.27   | 696.23  |
| 2011       | 608.74   | 695.64  |
| 2012       | 608.22   | 695.04  |
| 2013       | 607.70   | 694.44  |
| 2014       | 607.17   | 693.84  |
| 2015       | 606.65   | 693.25  |
| 2016       | 606.13   | 692.65  |
| 2017       | 605.61   | 692.05  |
| 2018       | 605.08   | 691.45  |
| 2019       | 604.56   | 690.85  |
| 2020+      | 604.04   | 690.26  |

## **B4 Fleet Composition Projections**

B4.1 The expressions describing vehicle emission rates as a function of speed were combined with fleet composition data to produce weighted average emission rates for a number of broader vehicle categories. The vehicle fleet model was compiled for the National Atmospheric Emissions Inventory (NAEI). The model provides a classification of vehicle type by vehicle kilometres travelled (using a classification system by type, age and fuel as outlined above for cars), and covers the period from 1996 to 2025.

B4.2 Where no local information on traffic composition is available to the user, the DMRB Screening method considers the traffic in two broad classes: light-duty vehicles and heavy-duty vehicles. For the DMRB Screening method, the disaggregated functions for the NAEI vehicle classes were combined into traffic-weighted average functions for these two vehicle groups. In order that the approach taken was again consistent with other applications of emission calculations, data on the composition and operation of road traffic in the UK were taken from the database compiled for the NAEI. The proportions of the detailed vehicle classes in the light-duty and heavy-duty vehicle categories will vary according to location. This is taken into account in the DMRB Screening Method via the use of different traffic compositions for three types of road:

- all motorways and A-roads;
- urban roads which are neither motorways nor A-roads;
- any other roads.

It was assumed that the detailed composition of the traffic on each road type would conform with national average statistics.

B4.3 Where local information on traffic composition is available to the user, the DMRB allows for the division of the traffic into passenger cars, LGVs, buses, rigid HGVs and articulated HGVs. Again, it was assumed that within each of these classes the distribution of vehicles according to fuel type, emission standard and engine size would conform with national average statistics.

B4.4 The aggregated emission functions described above for the different vehicle types do not take into account any local variations in certain aspects of traffic

composition (for example a specific road might carry an exceptionally high flow of old passenger cars). Nor do they reflect variations in emissions that might result from other local circumstances, such as steep hills or the presence of vehicles with cold engines. Depending on the nature of any deviations from the basic emission functions used here, concentrations may be under- or over-estimated.

B4.5 The fleet model was based on a number of assumptions. For example, it was assumed that diesel car sales will equilibrate at 20% of new car registrations. Also, a catalyst failure rate of 5% per annum is assumed for petrol vehicles (failed catalyst cars are included in the most recent non-catalyst class). For cars over three years old, which must pass an emissions test in the annual roadworthiness 'MOT' inspection, it is assumed that 98% of the failed catalysts are rectified, so these vehicles return to the catalyst class.

B4.6 Vehicle survival rates were derived from DETR vehicle licensing statistics on new registrations and age distribution. Annual mileages, as a function of the vehicle's age, were also derived from DETR statistics based on information from the National Travel Survey. The growth of new vehicle sales was based on the DETR Vehicle Market Model. The composition of the UK fleet was defined in terms of the proportion of vehicle kilometres travelled in a year by vehicles in each of the different Euro emission classes (Euro I, II etc.), and also the petrol/diesel mix in the case of cars and LGVs. For years up to 1999, composition data were based on DfT Vehicle Licensing Statistics, which give the age profile of the fleet each year from vehicle licensing records. These were combined with data from DfT on the changes in annual mileage with age to take account of the fact that, on average, newer vehicles travel a greater number of kilometres in a year than older vehicles. Figures from the Society of Motor Manufacturers and Traders (SMMT) were used to show the extent of early penetration of Euro III cars in the fleet before 2000. More details on the methods for deriving fleet composition can be found in the NAEI annual reports.

B4.7 Projections of the composition of the vehicle fleet from 2000 were derived from the turnover in the vehicle fleet and forecasts in the number of new vehicle sales. Fleet turnover was based on survival rate functions implied by historic vehicle licensing statistics (i.e. how many vehicles of different ages survive). Forecasts in new vehicle sales were provided by DfT's Vehicle Market Model, or linked to traffic growth

projections (e.g. the National Road Traffic Forecast). A number of other key assumptions affecting the composition of the fleet were made. These include:

- the penetration of diesel car sales in the new car market;
- the early introduction of Euro IV standards in the petrol car market;
- the fitting of particulate traps to some new light duty diesel vehicles.

B4.8 The assumptions were specified for the NAEI by DTLR in 2001, considering Government policy and most likely outcomes at the time and were used for the forecasts made for the Air Quality Strategy.

B4.9 For the carbon calculation the statistics relating to the evolution of the composition of the car fleet are different to those described above, and are taken from Web-TAG unit 3.6.5 Table 12.

# ANNEX C DEVELOPMENT OF THE SCREENING METHOD

## C1 Background

C1.1 The air quality assessment for a road scheme has two main elements. The first of these is the estimation of roadside air pollution concentrations, referred to as local impacts, associated with new or modified road schemes. The second is an estimation of total annual emissions arising from a road scheme, referred to as regional impacts. A Screening Method was developed to assist with the assessments associated with these two elements.

C1.2 The work of updating the Screening Method was undertaken on behalf of the Highways Agency (HA) by TRL in 2002. To assist with this process, the HA formed an advisory group that included representatives from the Department of the Environment, Food and Rural Affairs (Defra) and a number of their consultants, including Netcen, Air Quality Consultants and Casella Stanger. One of the main aims of this collaboration was to ensure consistency and compatibility with related applications such as those used for Local Air Quality Management (LAQM).

### The Local Air Quality Impacts of Road Projects

C1.3 Following introduction of a road project there may be localised changes in air quality in the immediate vicinity of all or part of the project, and changes may occur near to the existing road network. The pollutants considered in the local assessment are carbon monoxide (CO), benzene, 1,3-butadiene, nitrogen dioxide (NO<sub>2</sub>) and particles (PM<sub>10</sub>). The significance of the ambient concentration of a particular pollutant is usually assessed via reference to air quality criteria, and these were described in Annex A. The DMRB Screening Method provides a test that is designed to establish whether a road project ought to be subjected to a more detailed air quality assessment.

C1.4 In order to forecast the magnitude of possible impacts, it is necessary to compare current pollution levels with those anticipated in the future if the project is not built, and those anticipated if the project is built. As it is only possible to measure the first of these situations, it is necessary to compare modelled levels for all three cases to ensure that the comparison is made on a consistent basis. Changes in pollution levels will

result from factors such as changes in the road network and traffic, the general growth of traffic flows, and changes in vehicle emissions resulting from better emission control technologies and fuels. There are so many uncertainties with future air quality and its controls (vehicles are likely to become cleaner, traffic flows are likely to increase, air quality compliance criteria will tighten) that all assessments should address the base year and opening year of the project, with and without the proposals and for other years as appropriate. Results for the different assessment years should be evaluated against the relevant air quality criteria in those years.

### The Regional Air Quality Impacts of Road Projects

C1.5 As well as changes in local air quality following a road project, there may be changes in the overall quantity of emissions from the traffic on the road network. The pollutants considered in the regional assessment are CO, hydrocarbons (HC) (expressed as equivalent to the empirical formula CH<sub>1.85</sub>), oxides of nitrogen (NO<sub>x</sub>), PM<sub>10</sub> and carbon (C). To calculate a project's net contribution to overall air quality, it is necessary to calculate total forecast emissions after the proposed project has been built, and then subtract the estimated emissions from the existing road network where traffic patterns are affected by the project. The assessment should be conducted for the base year, the opening year and the design year of the project. The assessment method requires data on traffic flow, composition and speed for all road links affected by the project to be amalgamated with speed-related emission functions to determine the total emissions of selected pollutants.

C1.6 The procedure for local impact assessment is intended primarily to determine the likelihood of pollution concentrations arising that might be harmful to human health, as assessed by comparison with health-based air quality criteria. The pollutants also contribute to more widespread deterioration of air quality. Phenomena of this type depend more on the total amount of pollution in the atmosphere than on concentrations in a particular locality. The estimation of total pollutant emissions from traffic on a network is therefore required for the assessment.

C1.7 The DMRB Screening Method calculates area-wide emissions of CO, volatile organic compounds (VOCs), NO<sub>x</sub>, PM<sub>10</sub> and carbon. As the method for estimating total emissions is based on the same data and assumptions as that for local impact assessment, it is subject to the same uncertainties and approximations. In the case of localised evaluations, the effects of traffic changes on roads that are further than a few hundred metres from the location studied will be negligible, but they may be significant in terms of the project's effects on total emissions. The regional impact assessment should take into account all of a project's area of influence.

## **C2 Present and Future Vehicle Emission Functions**

C2.1 In order to estimate the exhaust emissions from traffic, it is necessary to know the traffic composition (because different vehicle types emit very different levels of pollution), the volume of traffic, and how the vehicles are being operated. Although a large number of operational factors will influence the emissions from traffic in specific locations, they cannot all be taken into account in the simplified, general-purpose procedure used in the DMRB Screening Method. They should be considered in situations where a detailed air quality impact assessment is necessary. For the DMRB screening assessment, only average vehicle speed is used to describe vehicle operating condition.

C2.2 The vehicle classification system used in the DMRB is shown in Table C1. In the DMRB, an emission function is assigned to each of these classes of vehicle, the difficulty being that for several of the classes emission factors have not been measured. There is an extensive database on emissions from cars of most types currently in use, but there is obviously no information on the in-use emissions performance of the future vehicle types (with the exception of limited data for manufacturers' prototypes), and very little for cars built to the most recent standards.

C2.3 In September 2001, a new database of emission functions<sup>27</sup> was produced for the Department for Transport. The derivation of the vehicle emission functions was described in more detail in Annex B. These algorithms express rates of emission (in g/km) as a function of average vehicle speed. These agreed functions are now used in both the DMRB and the NAEI.

---

<sup>27</sup> TRL Ltd. Exhaust emission factors 2001: Database and emission factors. Project Report PR/SE/230/00. 2001.

Table C1 Vehicle Classification Used in the DMRB

| Vehicle category   | Regulation                   | Vehicle category                | Regulation            |
|--|------------------------------|---------------------------------|-----------------------|
| Petrol cars<br><br>by engine size:<br><1.4 litres<br>1.4-2.0 litres<br>>2.0 litres | ECE 15.01                    | Rigid heavy goods vehicles      | Pre-1988              |
|  | ECE 15.02                    |                                 | Pre-Euro I (88/77EEC) |
|  | ECE 15.03                    |                                 | Euro I (91/542/EEC)   |
|  | ECE 15.04 + failed catalysts |                                 | Euro II               |
|  | Euro I                       |                                 | Euro III              |
|  | Euro II                      |                                 | Euro IV               |
|  | Euro III                     |                                 | Euro IV+              |
|  | Euro IV                      |                                 |                       |
| Diesel cars<br><br>by engine size:<br><2.0 litres<br>>2.0 litres                   | Pre-Euro I                   | Articulated heavy goods vehicle | Pre-1988              |
|  | Euro I                       |                                 | Pre-Euro I (88/77EEC) |
|  | Euro II                      |                                 | Euro I (91/542/EEC)   |
|  | Euro III                     |                                 | Euro II               |
|  | Euro III + particulate trap  |                                 | Euro III              |
|  | Euro IV                      |                                 | Euro IV               |
|  | Euro IV + particulate trap   |                                 | Euro IV+              |
| Petrol light goods vehicles  | Pre-Euro I                   | Buses                           | Pre-1988              |
|  | Euro I (93/59/EEC)           |                                 | Pre-Euro I (88/77EEC) |
|  | Euro II                      |                                 | Euro I (91/542/EEC)   |
|  | Euro III                     |                                 | Euro II               |
|  | Euro IV                      |                                 | Euro III              |
| Diesel light goods vehicles  | Pre-Euro I                   |                                 | Euro IV               |
|  | Euro I (93/59/EEC)           |                                 | Euro IV+              |
|  | Euro II                      |                                 |                       |
|  | Euro III                     |                                 |                       |
|  | Euro IV                      |                                 |                       |

### C3 Atmospheric Dispersion and Reaction

C3.1 Equations describing the decrease in pollutant concentrations with increasing distance from the road were derived from calculations using an atmospheric dispersion model. It was originally developed to forecast only CO concentrations, and has been extensively validated for that purpose. It has been assumed that the dispersion of other pollutants will be equivalent to that of CO, so that their concentrations

will be in the same proportions as their rates of emission. This assumption is likely to be valid for non-reactive gases, including VOCs and NO<sub>x</sub>. Due to their small size, exhaust particles also behave in a similar way to gases, though there may be some inaccuracies associated with the deposition of some particles, their agglomeration in the atmosphere and their possible adsorption of other atmospheric constituents such as water vapour. These dispersion profiles were further reviewed in a series of field measurements<sup>28</sup>.

<sup>28</sup> TRL Ltd. The measurement of roadside air pollution dispersion. TRL Report PR/SE/445/02, 2002.



C3.2 The contribution, in  $\mu\text{g}/\text{m}^3$  (atmospheric concentration) per g/km.hr (emission), of a stream of traffic to pollutant concentrations at a distance  $d$  from the road centre is given by the equations below. It is shown graphically in Figure C1. The equations are applied to each link separately.

If  $2\text{m} < d \leq 5\text{m}$ ,

$$\text{traffic contribution} = 0.063541 \mu\text{g}/\text{m}^3 \text{ per g}/\text{km.hr}$$

If  $5\text{m} < d \leq 168\text{m}$ ,

$$\text{traffic contribution} = 0.17887 + 0.00024 d - (0.295776/d) + (0.2596/d^2) - 0.0421\ln(d) \mu\text{g}/\text{m}^3 \text{ per g}/\text{km.hr}$$

If  $d > 168\text{m}$ ,

$$\text{traffic contribution} = 0.0017675 - (0.0000276173 \times (d - 168)) \mu\text{g}/\text{m}^3 \text{ per g}/\text{km.hr}$$

For CO, the calculated contribution (in  $\mu\text{g}/\text{m}^3$ ) must be divided by 1,000 to convert it to  $\text{mg m}^{-3}$ . No values are given for values of  $d$  smaller than 2m, and the user of the DMRB Screening Method cannot enter such values.

C3.3 The rate at which exhaust pollutants disperse depends on the atmospheric conditions, with the speed and direction of the wind being of particular

importance. In deriving the equation above, a wind speed of 2 m/s was assumed, and no weighting for wind direction was used (it was assumed that winds were evenly distributed around the compass). The assumed speed is rather lower than typically found in the UK, and the equation will tend, therefore, to overestimate pollution concentrations. Independence of wind direction allows the procedure to be applied without any knowledge of local conditions, but may lead to under- or overestimates of concentrations depending on the relative positions of roads and receptor locations with reference to locally prevailing winds.

C3.4 It should be noted that the dispersion equation represents the dispersion of the primary emissions from traffic on the road in question, and does not show the effects of chemical transformations or background contributions. When these are taken into account, different concentration profiles are produced for different pollutants.

#### C4 Comparison with Air Quality Criteria

C4.1 The results at this stage are estimates of the annual mean traffic-derived concentrations of CO, total hydrocarbons,  $\text{NO}_x$  and  $\text{PM}_{10}$ . However, the air quality criteria against which the forecast concentrations may be assessed are often expressed in different terms - either for different pollutants, different averaging periods (e.g. 8-hour average CO concentration), or

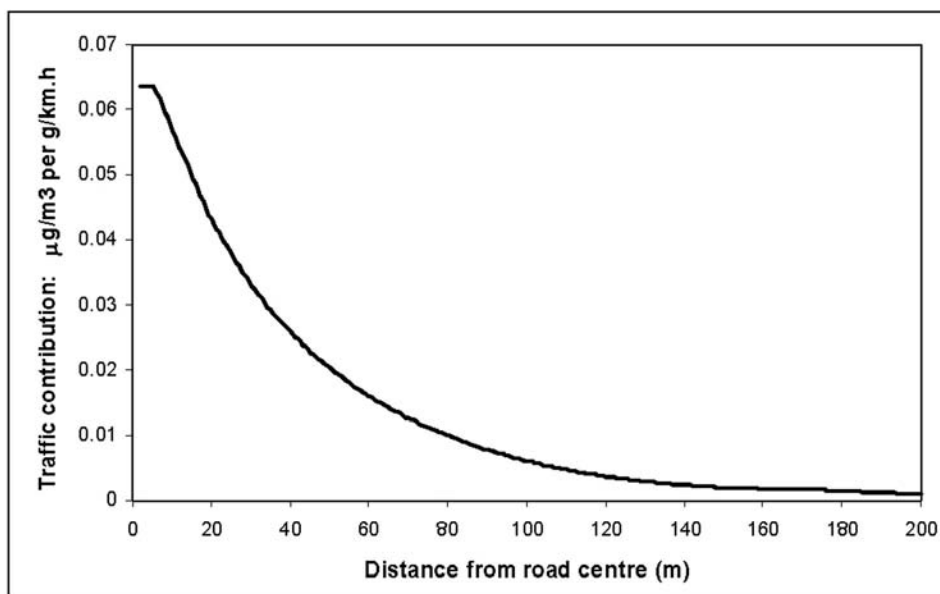

Figure C1 Traffic Contribution to Pollutant Concentration at Different Distances from the Road Centre

different frequencies of occurrence (e.g. number of exceedences of a 24-hour standard for PM<sub>10</sub>). Moreover, the local traffic contribution will be superimposed on an existing pollution background - from traffic outside the modelled area and other natural and anthropogenic sources. UK background pollution concentrations are estimated periodically by the NETCEN, on behalf of Defra. These maps are available with a spatial resolution of 1 km<sup>2</sup> for 2001 for all pollutants with updated versions for NO<sub>x</sub>, NO<sub>2</sub> and PM<sub>10</sub> for 2004, 2005 and 2010. Scaling factors are provided for other assessment years between 1996 and 2025. Alternatively, measured background concentrations can be used if available and scaled for future years.

C4.2 The final stage in the modelling procedure is to apply conversions so that the final estimated concentrations are compatible with the air quality criteria against which they will be assessed. The procedures differ for each pollutant, but were all derived empirically using data from the Defra network of air quality monitoring stations and the roadside monitoring network operated by TRL for the HA. Conversions to other pollutants, averaging times and frequencies of occurrence, in accordance with the metrics specified in the air quality criteria, are outlined below.

### Nitrogen Dioxide

C4.3 Although most of the NO<sub>x</sub> emissions from road traffic are in the form of NO, their impact must be evaluated in terms of their contribution to NO<sub>2</sub> levels in the air since these are subject to EU limit values and Air

Quality Strategy objectives, due to the effects of NO<sub>2</sub> on health. The NO<sub>2</sub> is formed primarily by reactions of NO in the atmosphere. An assumption that is implicit in the dispersion model used to derive this procedure is that there is no chemical interaction between pollutants or other atmospheric gases that will act to modify their concentrations differently from the physical dispersion processes. Oxides of nitrogen do not conform with the requirement of chemical stability.

C4.4 The main reaction by which NO is converted to NO<sub>2</sub> in the atmosphere is with O<sub>3</sub>:

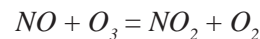

Where there is a large source of NO, such as the emissions from traffic on a road, the limiting factor on the production of NO<sub>2</sub> is the availability of O<sub>3</sub> with which the NO can react. At low concentrations of NO, there is sufficient O<sub>3</sub> in the air for its conversion to NO<sub>2</sub> to occur rapidly, but as the NO<sub>2</sub> concentration increases, the O<sub>3</sub> is depleted by the reaction until a stage is reached when none remains. After this stage, there is little effect on the concentration of NO<sub>2</sub>, even at much higher NO concentrations. This is shown in Figure C2, where hourly average concentrations of NO<sub>2</sub> and O<sub>3</sub> have been plotted in order of increasing NO<sub>x</sub> concentration. Ozone concentrations are highest when NO<sub>x</sub> is low. They fall steadily as both NO<sub>x</sub> and NO<sub>2</sub> levels increase. But, even though the highest NO<sub>x</sub> concentrations approach 1000 ppb, the NO<sub>2</sub> limit is little higher than that of the O<sub>3</sub> at low NO<sub>x</sub> concentrations. This means that the relationship between the annual mean concentrations of NO<sub>x</sub> and NO<sub>2</sub> is non-linear.

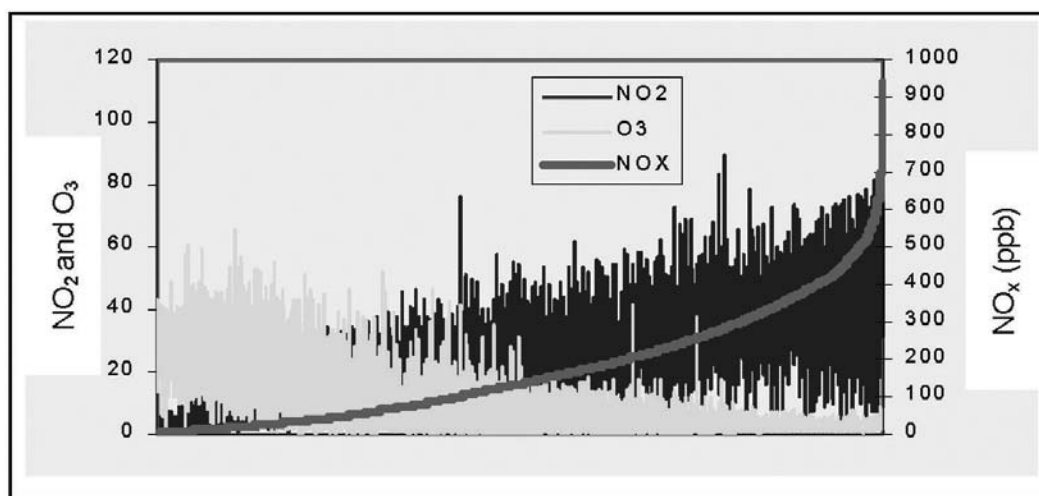

Figure C2 The Relationship Between Near-Road Concentrations of O<sub>3</sub>, NO<sub>2</sub> and NO<sub>x</sub>

C4.5 The implication of this is that increases in traffic flows will have a smaller effect on NO<sub>2</sub> concentrations than on NO<sub>x</sub>. Near to a busy road, there is nearly always a large excess of NO compared with O<sub>3</sub>, and production of NO<sub>2</sub> is therefore limited by the O<sub>3</sub> concentration rather than by the amount of emissions produced by the traffic. It should be noted that many other reaction mechanisms have been suggested to be important during episodes of extremely high pollution (QUARG 1993). The meteorological conditions that produce such episodes are when the atmosphere is very stable, with very light or no wind, and with a restricted mixing height so that pollutants cannot disperse into the upper layers of the air. For example, under those circumstances, the elevated concentrations of pollutants and their long residence in the local region can permit the formation of NO<sub>2</sub> by the reaction between NO and oxygen. There is no effective limit on the availability of oxygen to take part in that reaction, and the limiting factors then become the concentration of NO and the kinetics of the reaction. A pollution episode in December 1991 is thought to have resulted from these conditions, and in London NO<sub>2</sub> concentrations exceeded all previous records, peaking at a level in excess of 400 ppb. However, conditions such as these occur very infrequently. Depending on the duration of the meteorological episode, many other reactions leading to the formation of NO<sub>2</sub> are possible.

C4.6 The principles outlined above greatly simplify the true situation, in which many complex reaction mechanisms are involved. Ozone in the atmosphere is

itself created by reactions involving exhaust pollutants, so as pollution patterns change in the future, there will be corresponding changes in typical O<sub>3</sub> concentrations that will, in turn, modify the processes through which NO<sub>2</sub> is produced. Recent measurements have indicated a tendency towards an increase in annual mean ozone concentrations, but a reduction in the frequency and magnitude of concentration peaks.

C4.7 Because most NO<sub>2</sub> is formed through reactions of the type described, atmospheric NO<sub>2</sub> concentrations must be derived using a slightly different method to that used for the other pollutants. The approach<sup>29</sup> assumes that concentrations near to roads are made up of two components:

- NO<sub>2</sub> from the road traffic;
- NO<sub>2</sub> from the background air.

C4.8 The relationship between the atmospheric NO<sub>2</sub> and NO<sub>x</sub> concentrations due to road traffic was examined by subtracting the corresponding background values of NO<sub>2</sub> and NO<sub>x</sub> from the measured values at monitoring sites. The sites were predominantly from AURN, together with one local authority site near the M60 (provided by Salford MBC) and four HA roadside sites for the years 1999-2001. Information was provided by NETCEN on local background NO<sub>2</sub> and NO<sub>x</sub> for each monitoring location, using national 1x1 km<sup>2</sup> grid square maps for each of the three years. The data are shown in Figure C3.

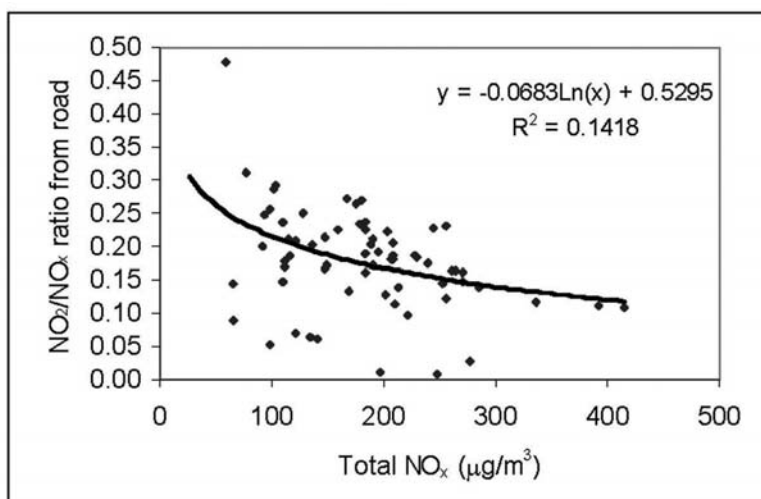

Figure C3 The Relationship Between the Ratio of NO<sub>x</sub> and NO<sub>2</sub> Contributions From Road Traffic and Total NO<sub>x</sub> Concentrations

<sup>29</sup> Laxen D and Wilson P (2002). A New Approach to Deriving NO<sub>2</sub> from NO<sub>x</sub> for Air Quality Assessments of Roads. Available at <http://www.defra.gov.uk/environment/airquality/laqm.htm>

The equation used to estimate total annual mean NO<sub>2</sub> is therefore:

$$NO_{2\ total} = NO_{2\ background} + NO_{2\ road}$$

Where NO<sub>2</sub> road is given by:

$$NO_{2\ road} = NO_{x\ road} [(-0.068 \ln (NO_{x\ total}) + 0.53)]$$

The second equation is derived from the data shown in Figure C3.

C4.9 The annual mean NO<sub>2</sub> concentration derived in this way is directly comparable to the annual mean air quality criteria for NO<sub>2</sub> (40 µg/m<sup>3</sup>). However, a conversion from the annual mean to the number of

exceedences the hourly NO<sub>2</sub> standard (200 µg/m<sup>3</sup>) is not now used in the DMRB. There are two reasons for this:

- (i) an evaluation of the monitoring data from the AURN sites revealed that the relationship between the number of hourly exceedences and the annual mean was very weak;
- (ii) there are very few exceedences of the hourly criteria at annual mean concentrations below 40 µg/m<sup>3</sup>, and therefore the annual mean criteria will almost always be exceeded first.

These observations are illustrated graphically in Figure C4.

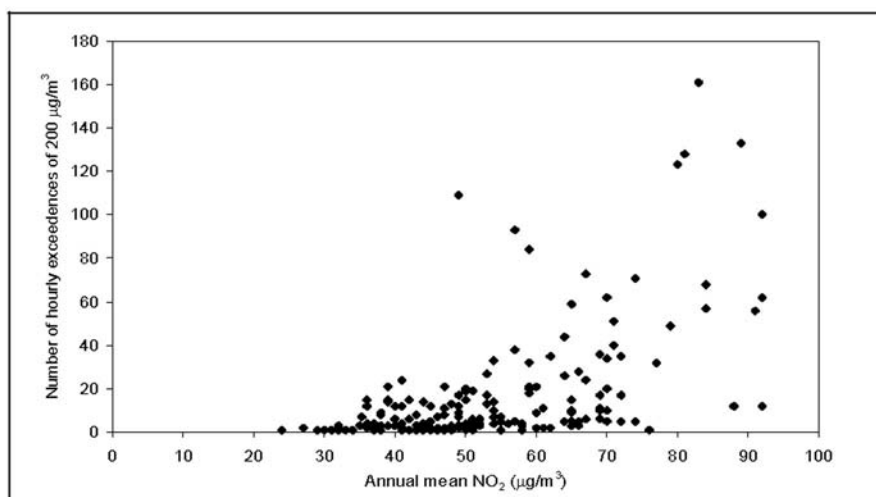

**Figure C4 Relationship Between Annual Mean NO<sub>2</sub> and Number of Hourly Exceedences of 200 µg/m<sup>3</sup> (1990 to 2001)**

### Carbon Monoxide

C4.10 In the case of CO, the road traffic contribution is added directly to the background concentration to give the absolute annual mean concentration. However, the air quality criteria for CO are defined in terms of a running 8-hour mean (10 mg/m<sup>3</sup>). As no exceedences of this standard are permitted, a relationship was required to relate the maximum 8-hour CO concentration during a year with the annual mean. Carbon monoxide is an inert gas (on the timescale of near-road dispersion processes) and is predominantly emitted by road traffic sources, so there are reasonably consistent relationships between the annual mean concentration and those for other averaging periods and frequencies. This is not the case, however when the absolute maximum 8-hour

concentration is considered. The evaluation of the monitoring data from the AURN sites over a period of several years revealed that the relationship between the maximum 8-hour concentration and the annual mean was very weak, with a great deal of scatter (Figure C5). Consequently, only the annual mean CO concentration is reported. It should, however, be noted that exceedences of the CO standard have been extremely rare in recent years (although some exceedences of the CO standard in Figure C5 are apparent, the graph does include data going back to 1990), even at the busiest roadside sites, and if the annual mean is less than 2 mg/m<sup>3</sup> then it is currently unlikely that the criteria will be exceeded (see 1998-2001 data in Figure C5). The evaluation of CO (as the annual mean) is included more for completeness than in the expectation of any exceedences of the criteria.

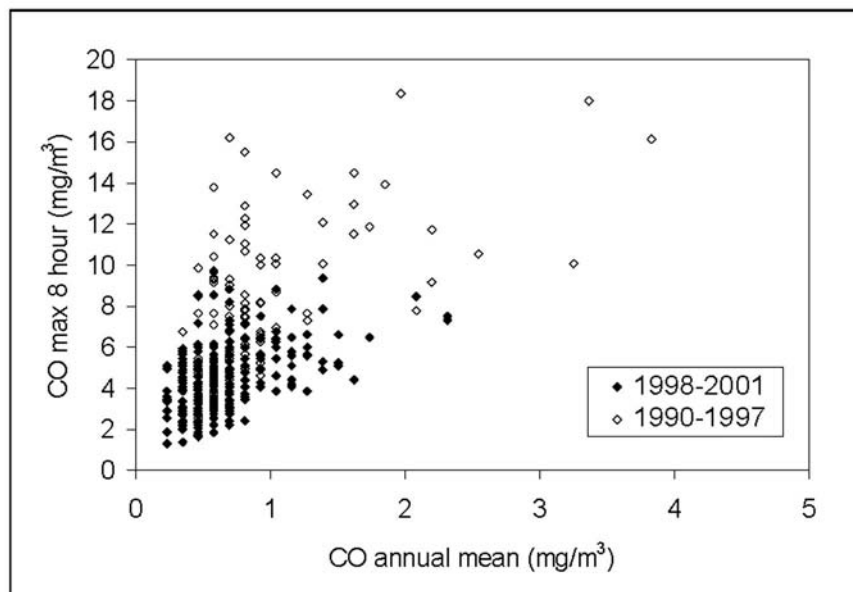

Figure C5 Relationship Between Maximum 8-Hour CO and Annual Mean CO for 1990-2001

**Particulate Matter**

C4.11 The annual mean road traffic PM<sub>10</sub> contribution calculated by the DMRB is added directly to the background concentration to give the absolute annual mean concentration. The annual mean PM<sub>10</sub> can then be compared directly with the annual mean standards. Information on the size distribution of vehicle exhaust particles shows them predominantly to be much smaller than 10 µm in diameter, with most (by mass) in the size fraction less than 1 µm. It is therefore acceptable to

regard the total particle emissions conventionally measured in vehicle tests as equivalent to PM<sub>10</sub>. There is also a 24-hour mean standard for PM<sub>10</sub> of 50 µg/m<sup>3</sup>, not to be exceeded more than 35 times a year. The evaluation of the monitoring data from the AURN sites revealed that the relationship between the number of exceedences of the 24-hour standard and the annual mean was good (Figure C6). The equation to derive the number of exceedences (*N*) from the annual mean (*a*) is:

$$N = -18.5 + 0.00145a^3 + (206/a)$$

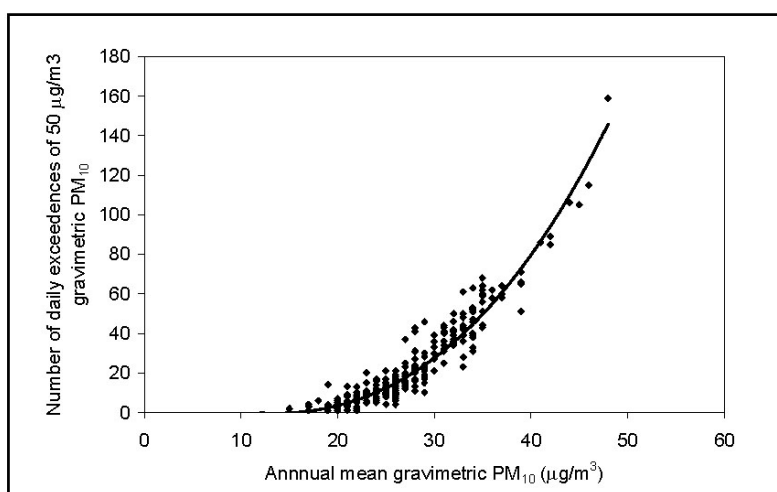

Figure C6 Relationship Between Annual Mean and Number of Exceedences of 50 µg/m<sup>3</sup> Gravimetric PM<sub>10</sub>

C4.12 Of all of the pollutants considered, PM<sub>10</sub> has the lowest direct contribution from road transport emissions. A significant proportion of airborne particles is secondary in nature (derived in part from vehicle emissions, but generated by large-scale atmospheric processes and adding, therefore, to the general regional pollution background), non-transport combustion, and non-combustion sources such as mining, quarrying and construction also produce primary particles and the precursors of secondary particles, and there are natural sources such as fungal spores and sea salt. Furthermore, for particles it has been shown that some episodes of high-pollution are dominated by material transported over very large distances. On average in 1996, between a quarter and a half of the sulphate pollution in the UK was derived from sources in mainland Europe. For these reasons, the effects of a road project on PM<sub>10</sub> concentrations are less marked than those on concentrations of other pollutants.

#### **Benzene and 1,3-Butadiene**

C4.12 For each of these two pollutants, the road traffic contribution calculated by the DMRB Screening Method is added directly to the background concentration to give the absolute annual mean concentration. This can then be compared directly with the appropriate air quality criterion.

### **C5 Calibration of the Local Assessment Method**

C5.1 The DMRB Screening Method was modified to include the latest information on emission factors, fleet composition, background concentrations, the relationship between NO<sub>x</sub> and NO<sub>2</sub>, and the relationships between the annual mean concentrations and the metrics specified in the air quality criteria.

C5.2 Data were assembled detailing pollutant concentrations and traffic conditions at a selection of roadside measurement sites from the AURN, local authority, and HA networks. Using these data and the new DMRB spreadsheet, estimates were made of annual mean concentrations of CO, benzene, 1,3-butadiene, NO<sub>x</sub>, NO<sub>2</sub> and PM<sub>10</sub>. A comparison between these estimates and the corresponding measured concentrations revealed that there remained significant differences.

C5.3 Further investigation showed that the ratio of the predicted road traffic contribution to the concentrations of CO, NO<sub>x</sub> and PM<sub>10</sub> can be described as a function of traffic flow (weighted for distance from the receptor where more than one road is being considered). The application of these functions to the road traffic component substantially improved the prediction accuracy of the method, and they have been incorporated into the DMRB spreadsheet. NO<sub>2</sub> concentrations were derived from the adjusted NO<sub>x</sub> concentrations using the method described earlier. A comparison of modelled with measured concentrations showed that there was good agreement at the majority of AURN and HA monitoring sites. Further information is available on the calibration<sup>30</sup>. For benzene and 1,3-butadiene, no adjustments could be made due to the lack of measurement data. There remains a great deal of uncertainty in both the emissions factors and the estimated concentrations for these two pollutants. In particular, it is likely that the 1,3-butadiene concentration is significantly over-predicted.

C5.4 Since the Screening Method was calibrated, the Air Quality Archive background concentrations for NO<sub>2</sub>, NO<sub>x</sub> and PM<sub>10</sub> have been revised providing data for 2004, 2005 and 2010. In rural areas, these revised background concentrations for NO<sub>x</sub> and NO<sub>2</sub> tend to be generally lower. This means that it is particularly important that predicted concentrations are compared with measurements as the calibration factors included in the Screening Method were developed using different background concentrations.

### **C6 Limitations of the 'Local' Assessment Method**

C6.1 The DMRB Screening Method is a screening method and so is intended to give a reliable answer quickly. It does not take into account a number of factors that could affect concentrations. If these are important to your scheme, then a detailed approach should be taken. It does not take account of:

- emissions from tunnel portals;
- the effect of cuttings/embankments/barriers/vegetation;
- street canyons (in detail);

<sup>30</sup> TRL Ltd. Update to the DMRB Air Quality Screening Method: Calibration Report. TRL Report PA/SE/3908/02, 2002. Available at <http://www.trl.co.uk/>

- changes to the proportion of primary NO<sub>2</sub> in vehicle emissions;
- changes to background ozone concentrations;
- local meteorological conditions including prevailing wind direction;
- peak hour congestion (explicitly);
- Euro V emission standards and beyond.

## ANNEX D USING THE DMRB SCREENING METHOD

### D1 The Road Network

D1.1 For an assessment of exposure at a particular receptor, the roads included in the calculation should be all those expected to make a significant contribution to pollution at the receptor location in question. In practice, roads more than 200 m away from the receptor can be excluded. The selection of roads can often be made using a large-scale map, together with basic traffic flow data. Where there is uncertainty as to the likely impact of roads in the area, a site inspection is recommended.

### D2 Road Type

D2.1 A road type definition must be given for each road included in the assessment. The DMRB Screening Method has been configured with three broad road categories. These are:

|            |   |   |
|------------|---|---|
| Category A | = | All motorways or A-roads                            |
| Category B | = | Urban roads which are neither motorways nor A-roads |
| Category C | = | Any other roads                                     |

D2.2 Where the user has information on the composition of the traffic, this should be used in preference to the default values. In this case, the road type definition is not appropriate (labelled category 'D').

### D3 Traffic Data

D3.1 Traffic characteristics must be specified for each road in the network under consideration. The revised DMRB Screening Method allows the traffic to be described in two ways.

- In terms of the AADT flow and the proportion of light-duty and heavy duty vehicles (defined respectively as those vehicles with a gross vehicle weight below and above 3.5 tonnes). Depending on the assessment year and road type, the model will refer to a database to derive a more detailed composition for each broad vehicle type. The resulting subdivision will give the national average composition with respect to type

(car, light goods vehicle, bus, coach, rigid lorry or articulated lorry), size (engine capacity or weight), fuel (petrol or diesel) and the emission standard.

- Where local traffic classification data are available, these should be used in preference, as it is possible for the local traffic composition to differ significantly from the national average. Data should be given as individual percentages of cars, light goods vehicles, buses/coaches, rigid lorries and articulated lorries. Because it is not simple to observe many of the other variables used in the detailed classification (such as fuel type or emission standard), the model again performs that subdivision using national data.

D3.2 Vehicle emission rates are calculated as a function of average speed. The highest emissions are normally associated with slow speed, congested driving conditions, with the lowest emissions during steady speed operation at an average speed of around 60-80 km/h. The DMRB Screening Method uses annual average vehicle speed as an input parameter. Where no information is available on average speeds and no estimate can be made, then the speed limit may be used as a default. However, given that changes in average speed may have significant impacts on the estimated rates of emission, sensitivity tests using various speeds should be carried out to determine if detailed investigation of the speed is warranted.

### D4 Definition of Road Links

D4.1 The road network within the study area should be divided into sections where traffic conditions (flow, composition and average speed) are reasonably homogeneous. The road network should be divided into as few continuous roads as possible to avoid overestimation by including contributions separately from different parts of the same road. This is often true even when a road is not straight or is interrupted by a roundabout, crossroad or other feature. There will be situations where a short section of road is not part of a longer continuous road and it must be considered as a separate contributor. The data necessary for each link are essentially those described above, but there are slight differences in the approaches for local and regional assessments.



- For local assessments, it is necessary to consider the traffic characteristics at the point nearest to the receptor. Thus, for example, the average speed over a whole link is likely to be higher than that on the same link, but near to a roundabout. If the receptor is close to the roundabout, the lower, localised average speed should be used. This applies to all other traffic data. It is also necessary to specify the distance between the receptor and the centre of each link.
- For regional assessments, which take into account each link in its entirety, the average properties should be used. The length of the link is also required.

D4.2 The network and network link divisions made are to be shown on a map, with traffic data for each link shown. The principles of road link definition for local assessments are illustrated in the examples given below.

**Example 1:**

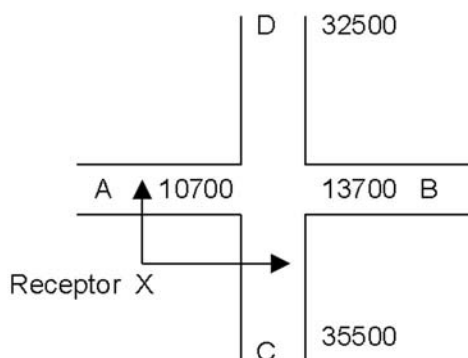

This simple network should be divided into 2 links, AB and CD. For the receptor at X, the distances would be as shown by the arrows. The traffic flows (and other data) would be those on the arms of the crossroad nearest to X. Thus, for link AB, the appropriate flow would be 10,700 and for CD 35,500.

**Example 2:**

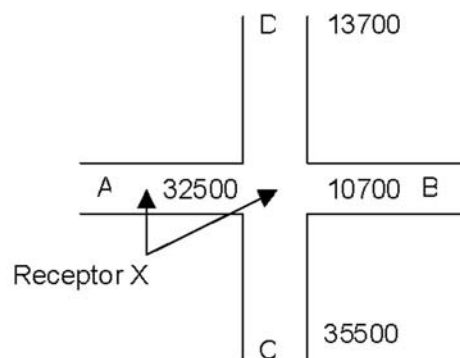

This is the same network as for Example 1, but now it has been assumed that the major flow of traffic takes the route AC. Because road designations are based on homogeneous traffic characteristics rather than geometry, the two links in this case are AC and BD. The closest position to the receptor on link BD is now at the centre of the crossroad, as shown. This point is common to both arms of the link, so the traffic data should be the average, rather than that specific to either of them. Thus, the appropriate flow would be 12,200.

**Example 3:**

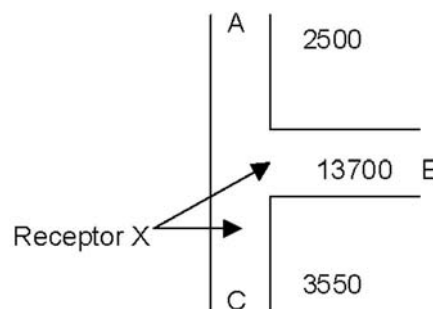

Again, this simple network reduces to two links. On the basis of the traffic flows, arms A and C are most similar (a difference of 10,500 compared with a difference of 11,300 between A and B). The continuous link is therefore designated AC, with the remaining arm, B, becoming the second link. The arrows show the closest distances between the links and the receptor. The appropriate flow for Link AC is 35,500 because the receptor is closer to arm C than arm A. That for link B would be 13,700.

**Example 4:**

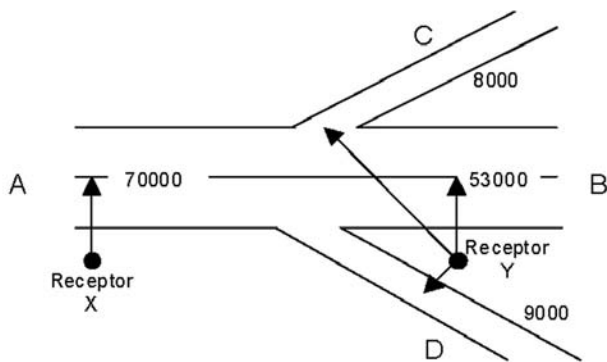

This example represents a motorway or dual-carriageway road (AB) with entry and exit slip roads. AB has a traffic flow of 70,000 west of the junction, and a flow of 53,000 east of the junction. The flow on the northern slip road (C) is 8,000, and the flow on the southern slip road is 9000. At a receptor located away from the junction (X), only the flow on the main link need be considered. For a receptor located within the area bounded by the junction, all three links (AB east of the junction, and both slip roads) need to be considered as shown.

**Example 5:**

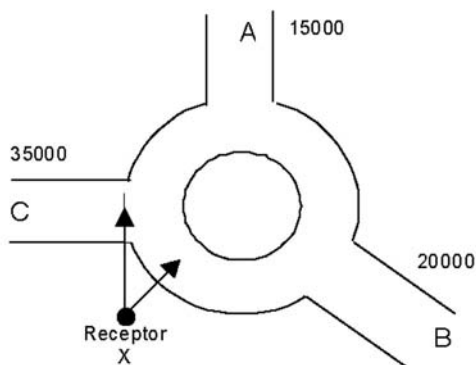

Even though this network includes a roundabout, it is similar to the three-arm junction in Example 3. The two arms with the most similar traffic conditions are considered as one link and the remaining arm forms the second. Thus, the first link is AB, and the second is C. However, the presence of the roundabout influences the

positions on the roads to which measurements are taken as it has the effect of bringing some of the traffic nearer to the receptor. The distance to link C is measured normally, but that to AB is taken to a point on the roundabout. The flow on AB is taken to be the average of that on arms A and B.

**Example 6:**

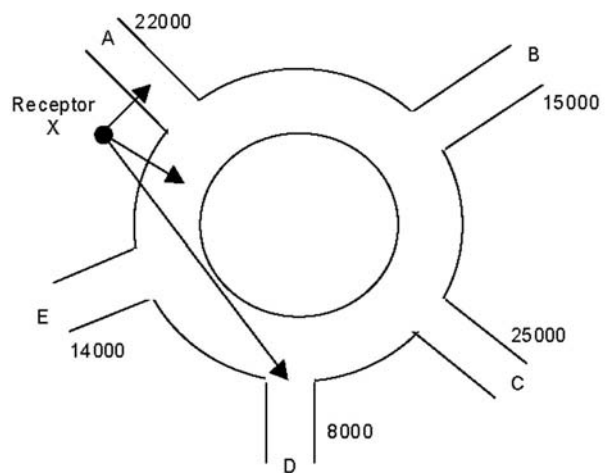

This example shows a five-arm roundabout. This can be reduced to three links as follows. On the basis of the traffic flows, arms A and C are similar, and therefore AC becomes a link, with the distance being measured to the nearest point on arm A. Arms B and E are also similar, and so BE also becomes a link, with the distance being measured to the nearest point on the roundabout and the flow being the average of those on the two arms. The remaining arm, D, becomes the third link. The distance to arm D is measured to the point at which arm D joins the roundabout.

**D5 Local Background Concentrations**

D5.1 For local impact assessments it is necessary to specify background concentrations upon which the local, traffic-derived pollution is superimposed. They may be derived through local long-term ambient measurements at background sites, remote from immediate sources of air pollution, but such data are rarely available. Background concentrations may be obtained from a series of default concentration maps<sup>31</sup> produced periodically by NETCEN, on behalf of Defra.

<sup>31</sup> Background pollution data may be obtained from LAQM section of the NETCEN website at <http://www.airquality.co.uk>

D5.2 While the mapped background concentrations may be directly appropriate for most urban situations, for which several monitoring sites have been used for verification, there are few measurements available for rural locations. An analysis of the rural background concentrations allocated to individual grid squares containing road links indicates that they may be unduly influenced by the road. It is then inappropriate to add a second contribution from the road. Where this issue is considered significant, it is recommended that concentrations are used derived from the average background concentration up to four grid squares away from either side of the road where there are no other significant sources of pollution.

### D6 Preparation of Input Tables

D6.1 The data assembled in the way described above should now be assembled into tables in preparation for their input to the spreadsheet. There are small

differences between the tables for local impact assessment and those for regional impact assessment.

- I. For local assessments data should be provided for each link under the headings shown in Figure D1, and include the distance from the link to the receptor in addition to the traffic flow and composition details. One such table is needed for each receptor location to be evaluated, and for each year under consideration.
- II. For regional impact assessments most of the necessary data are identical, but since this evaluation is not made with respect to any individual location, the distance to receptor column is replaced by the link length (Figure D2). An option is also provided to give a title to each link (the street name, for example). This may be helpful in identifying the contributions made by particular parts of the network.

| Link number | Distance from link centre to receptor (m) | Traffic flow & speed    |                             |                     | Traffic composition |                        |             |                          |             |                   |             |
|-------------|---|-------------------------|-----------------------------|---------------------|---------------------|------------------------|-------------|--------------------------|-------------|-------------------|-------------|
|             |   | AADT (combined) veh/day | Annual average speed (km/h) | Road type (A,B,C,D) | Vehicles <3.5t GVW  |                        |             | Vehicles >3.5t GVW (HDV) |             |                   |             |
|             |   |                         |                             |                     | % cars              | % light goods vehicles | Total % LDV | % buses and coaches      | % rigid HGV | % articulated HGV | Total % HDV |

Figure D1 Input Data for Local Assessment

| Link number | Link title | Link length (km) | Traffic flow & speed    |                             |                     | Traffic composition |                        |             |                          |             |                   |             |
|-------------|------------|------------------|-------------------------|-----------------------------|---------------------|---------------------|------------------------|-------------|--------------------------|-------------|-------------------|-------------|
|             |            |                  | AADT (combined) veh/day | Annual average speed (km/h) | Road type (A,B,C,D) | Vehicles <3.5t GVW  |                        |             | Vehicles >3.5t GVW (HDV) |             |                   |             |
|             |            |                  |                         |                             |                     | % cars              | % light goods vehicles | Total % LDV | % buses and coaches      | % rigid HGV | % articulated HGV | Total % HDV |

Figure D2 Input Data for Regional Assessment

### D7 Instructions for Spreadsheet Operation

D7.1 The DMRB Screening Method Spreadsheet was developed in Microsoft Excel 97, but is compatible with more recent versions of Excel.

D7.2 The method is contained in a multi-sheet spreadsheet, with five of these sheets immediately accessible by the user. These sheets are as follows:

- I. **Title:** This is the title page of the spreadsheet, indicating the version number of the method and the release date.

- II. **Local:** This is the sheet to be used for inputting data for the assessment of local air quality in relation to both road project appraisal and local authority review and assessment.

- III. **Local output:** This sheet presents the results of the assessment of local air quality. The concentrations of pollutants are stated as annual means, and according to the metrics specified in the air quality criteria. In addition, a table is included to show the contribution of each separate link to the annual mean concentrations estimated for a receptor point.

IV. **Regional:** This is the sheet to be used for inputting data for the regional impact assessment of road projects on road transport emissions.

V. **Regional output:** This sheet presents the results of the regional assessment of the impact of road projects on road transport emissions.

In addition to these five sheets, a sixth sheet, entitled *Calc*, is visible whenever any calculations are being made by one of the macros. This sheet is not visible at any other time.

In order to assist the user, comments are linked to some of the cells to provide definitions and details of the required input data. The presence of a comment is indicated by a red triangle in the top right-hand corner of a cell.

### Method for Assessment of Local Air Quality

D7.3 The procedure in the Screening Method spreadsheet for the assessment of local air quality involves seven steps. These steps are highlighted on the *Local* sheet, and are as follows:

Step 1 Enter the receptor name and number ('1' for first receptor, '2' for second, and so on). Up to 20 different receptors can be assessed (one at a time), with each one requiring a unique identification number. If the results for a specified receptor number are already present on the **Local** output sheet, the program will ask for a different receptor number.

Step 2 Enter the assessment year (between 1996 and 2025).

Step 3 Enter the number of links to be assessed for the current receptor. Up to 15 different links can be assessed. In most cases, carriageways on the same road must not be entered separately. Where the two carriageways are grade separated, or take different routes, they should be assessed individually.

Step 4 Enter the background concentrations which are relevant to the locality of the assessment for the assessment year. If there is no requirement to assess a particular pollutant, a zero can be entered as the background value. A result will still be presented for the pollutant on the Local output sheet, but this can be ignored.

Step 5 Enter the distance and traffic data for each link. The number of links specified here must match that defined in Step 3, and the following input data are required:

- The distance in metres from the link centre to the receptor. The minimum distance allowed is 2 m.
- The combined annual average total daily traffic flow (AADT).
- The annual average traffic speed in km/h. This must be between 5 km/h and 130 km/h.
- The road type

Enter either 'A', 'B', 'C' or 'D' in upper case or lower case, but not a mixture of both. If information on the traffic composition on the link is not available, enter either 'A', 'B', or 'C', where:

A = Motorways or A-roads

B = Urban roads which are neither motorways nor A-roads

C = All other roads

When a valid entry is made, the cell shading will change to light grey to indicate which type of traffic composition must be used (see below).

Where information on actual traffic composition is available from classified counts, this may be used in place of the pre-set traffic compositions by entering 'D' in the road type cell. If 'D' is entered in a cell, the cell shading will change to dark grey.

- The traffic composition

If either 'A', 'B', or 'C' has been entered in the road type cell, then only the total percentages of heavy-duty vehicles (HDVs) and light-duty vehicles (LDVs) need to be entered in the appropriate light grey cells. The dark grey cells must be left blank.

If 'D' has been entered in the road type cell, the percentage of vehicles in each of the following five classes must then be entered:

- i. passenger cars;
- ii. light goods vehicles;

- iii. buses and coaches;
- iv. rigid heavy goods vehicles (>3.5 tonnes gross vehicle weight);
- v. articulated heavy goods vehicles (>3.5 tonnes gross vehicle weight).

The appropriate values are entered in the corresponding dark grey cells. The light grey cells must be left blank.

Step 6 Click on 'CALCULATE'. During the calculation a message will appear on the screen to indicate the percentage of the calculation which has been completed. When the calculation has been completed, a 'RUN COMPLETE' message appears, and the results for the current receptor can then be viewed on the **Local output** sheet. If only one receptor is to be assessed, the procedure ends at this point. The **Local output** sheet displays the details of the current receptor (name, number, and assessment year), the predicted concentrations for the receptor.

The results for CO, benzene, 1,3-butadiene, NO<sub>x</sub>, NO<sub>2</sub> and PM<sub>10</sub> are presented as annual mean concentrations<sup>32</sup>. For PM<sub>10</sub> the number of days with concentrations above 50 mg/m<sup>3</sup> is also given.

Step 7 In some assessments, there may be a need to look at several receptors. If this is the case, the results for the current receptor can be stored on the Local output sheet by pressing the STORE RESULTS FOR THIS RECEPTOR button on the Local sheet. Enter data for the next receptor by overwriting the input data already present, or start from scratch by pressing the CLEAR INPUT DATA button.

### Method for Regional Impact Assessment

D7.4 The regional impact assessment method involves five steps. These steps are highlighted on the **Regional** sheet, and are as follows:

Step 1 Enter the identifying name for the assessment.

Step 2 Enter the assessment year (1996-2025).

Step 3 Enter the number of links to be assessed. Up to 1,000 different links can be assessed.

Step 4 Either:

Enter the data for each link. The number of links specified here must match that defined in Step 3, and the following input data are required:

- Title of the link (optional).
- Length of the link in km.
- Combined annual average total daily traffic flow (AADT).
- Annual average traffic speed in km/h. This must be between 5 km/h and 130 km/h.
- Road type defined in the same way as in the local air quality assessment.
- Traffic composition defined in the same way as in the local air quality assessment.

Or:

Import the link data as an Excel spreadsheet or a tab-delimited text file. In order to import link data, click on the IMPORT LINK DATA (.xls or .txt) button. This will open the 'Data File to Import' dialogue box. Locate the data file and click on 'Open'. In order to be imported correctly the data file must be in the following format:

<sup>32</sup> For CO the air quality criteria are for a running 8-hour mean of 10 mg/m<sup>3</sup>. However, as there is no strong relationship between the CO annual mean and the running 8-hour mean it is not possible to calculate the latter from the annual mean with a high degree of confidence. Therefore, only the annual mean value is reported. The NO<sub>2</sub> criteria are defined in terms of both the annual mean of 40 µg/m<sup>3</sup>, and the number of exceedences of a 1-hour mean of 200 µg/m<sup>3</sup>. Whilst the annual mean NO<sub>2</sub> value is calculated, the number of exceedences of the hourly standard cannot be calculated from the annual mean with a high degree of confidence. Therefore, as with CO, only the annual mean NO<sub>2</sub> value is reported.

**Excel data file:**

The Excel data file must take the format shown below, with a header line at Row 1. The header line may be left blank.

Alternatively, if the data file is in the correct Excel format, the data from Row 2 onwards can simply be copied into the Regional sheet at Cell at the Link title position for link number 1.

**Text data file:**

The tab-delimited text data file is essentially the same and must be defined in the following way:

Line 1: [Identifying name]

Following lines: [Link title]{TAB}[Link length] {TAB} [AADT] {TAB} [Speed] {TAB} [Road type] {TAB} [%PC] {TAB} [%LGV] {TAB} [Total %LDV] {TAB} [%Buses] {TAB} [%Rigid HGV] {TAB} [%Artic HGV] {TAB} [Total %HDV]

Where an entry is not required (e.g. %PC is not required for road types A, B or C) the field is left blank.

Step 5 Click on 'CALCULATE'. (**Warning:** this clears any existing output). The calculation may take a few hours if there are several hundred links to process. During the calculation a message will appear on the screen to indicate the percentage of the calculation which has been completed. When the calculation has been completed, a 'RUN COMPLETE' message appears, and the results for the current receptor can then be viewed on the Regional output sheet. The Regional output sheet displays the summarised details of the current assessment (name, assessment year, and number of links), and the predicted total emissions of CO, THC, NO<sub>x</sub>, PM<sub>10</sub> and CO<sub>2</sub> on the defined network.

**Worked Examples**

D7.5 This section shows how the Screening Method should appear during the local and regional assessments. The network used in the local assessment is taken to be Example 1 from paragraph 3.23.

D7.6 Figure D3 illustrates the input sheet for the local air quality assessment with the appropriate details entered for Example 1. Some typical traffic speeds, traffic composition, and background concentrations have been used. Figure D4 shows the outputs.

| <i>DMRB: Assessment of Local Air Quality</i> |   |                              |                                    |                                      |                                      | INPUT SHEET                           |                          |                     |             |                   |             |    |
|--|---|------------------------------|------------------------------------|--------------------------------------|--------------------------------------|---------------------------------------|--------------------------|---------------------|-------------|-------------------|-------------|----|
| Step 1                                       | Receptor name                             | Example 1                    | Receptor number                    | 1                                    |                                      | Step 6                                |                          |                     |             |                   |             |    |
| Step 2                                       | Year                                      | 2006                         |                                    |                                      |                                      | Step 7                                |                          |                     |             |                   |             |    |
| Step 3                                       | Number of links                           | 2                            |                                    |                                      |                                      |                                       |                          |                     |             |                   |             |    |
| Step 4                                       | Background concentrations for 2006        |                              |                                    |                                      |                                      |                                       |                          |                     |             |                   |             |    |
|  | CO (mg/m <sup>3</sup> )                   | Benzene (µg/m <sup>3</sup> ) | 1,3-butadiene (µg/m <sup>3</sup> ) | NO <sub>x</sub> (µg/m <sup>3</sup> ) | NO <sub>2</sub> (µg/m <sup>3</sup> ) | PM <sub>10</sub> (µg/m <sup>3</sup> ) |                          |                     |             |                   |             |    |
|  | 0.29                                      | 0.4                          | 0.17                               | 33.4                                 | 21.6                                 | 14                                    |                          |                     |             |                   |             |    |
|  |   |                              |                                    |                                      |                                      | RUN COMPLETE                          |                          |                     |             |                   |             |    |
| Step 5                                       | Traffic flow & speed                      |                              | Traffic composition                |                                      |                                      |                                       |                          |                     |             |                   |             |    |
| Link number                                  | Distance from link centre to receptor (m) | AADT (combined, veh/day)     | Annual average speed (km/h)        | Road type (A,B,C,D)                  | Vehicles <3.5t GVW (LDV)             |                                       | Vehicles >3.5t GVW (HDV) |                     |             |                   |             |    |
|  |   |                              |                                    |                                      | % passenger cars                     | % light goods vehicles                | Total % LDV              | % buses and coaches | % rigid HGV | % articulated HGV | Total % HDV |    |
| 1  | 10  | 10700                        | 36                                 | A                                    |                                      |                                       | 90                       |                     |             |                   |             | 10 |
| 2  | 25  | 35500                        | 15                                 | D                                    | 82                                   | 6                                     |                          | 1                   | 8           | 3                 |             |    |
| 3  |   |                              |                                    |                                      |                                      |                                       |                          |                     |             |                   |             |    |
| 4  |   |                              |                                    |                                      |                                      |                                       |                          |                     |             |                   |             |    |
| 5  |   |                              |                                    |                                      |                                      |                                       |                          |                     |             |                   |             |    |

Figure D3 Example Spreadsheet: Input to Local Assessment

| DMRB: Assessment of Local Air Quality                       |                          |                        |       |                   |   |       |                   | OUTPUT SHEET                                    |                         |                              |                                    |                                      |                                       |
|---|--------------------------|------------------------|-------|-------------------|---|-------|-------------------|---|-------------------------|------------------------------|------------------------------------|--------------------------------------|---------------------------------------|
| <b>Current receptor</b>                                     |                          |                        |       |                   |   |       |                   |   |                         |                              |                                    |                                      |                                       |
| Receptor Name   |                          | Example 1              |       |                   | Receptor number                           |       | 1                 |   |                         |                              |                                    |                                      |                                       |
| Assessment year   |                          | 2006                   |       |                   |   |       |                   |   |                         |                              |                                    |                                      |                                       |
| <b>Results</b>  |                          |                        |       |                   |   |       |                   |   |                         |                              |                                    |                                      |                                       |
| Pollutant   | Annual mean              |                        |       |                   | For comparison with Air Quality Standards |       |                   | <b>Contribution of each link to annual mean</b> |                         |                              |                                    |                                      |                                       |
|   | Background concentration | Road traffic component | Total | Units             | Metric                                    | Value | Units             | Link number                                     | CO (mg/m <sup>3</sup> ) | Benzene (µg/m <sup>3</sup> ) | 1,3-butadiene (µg/m <sup>3</sup> ) | NO <sub>x</sub> (µg/m <sup>3</sup> ) | PM <sub>10</sub> (µg/m <sup>3</sup> ) |
| CO  | 0.29                     | 0.27                   | 0.56  | mg/m <sup>3</sup> | Annual mean*                              | 0.56  | mg/m <sup>3</sup> | 1   | 0.07                    | 0.07                         | 0.11                               | 26.55                                | 3.10                                  |
| Benzene   | 0.40                     | 0.36                   | 0.76  | µg/m <sup>3</sup> | Annual mean                               | 0.76  | µg/m <sup>3</sup> | 2   | 0.20                    | 0.29                         | 0.52                               | 58.63                                | 7.35                                  |
| 1,3-butadiene   | 0.17                     | 0.63                   | 0.80  | µg/m <sup>3</sup> | Annual mean                               | 0.80  | µg/m <sup>3</sup> | 3   |                         |                              |                                    |                                      |                                       |
| NO <sub>x</sub>   | 33.4                     | 85.2                   | 118.6 | µg/m <sup>3</sup> | Not applicable                            |       |                   | 4   |                         |                              |                                    |                                      |                                       |
| NO <sub>2</sub>   | 21.6                     | 17.3                   | 38.9  | µg/m <sup>3</sup> | Annual mean*                              | 38.9  | µg/m <sup>3</sup> | 5   |                         |                              |                                    |                                      |                                       |
| PM <sub>10</sub>  | 14.0                     | 10.45                  | 24.45 | µg/m <sup>3</sup> | Annual mean                               | 24.4  | µg/m <sup>3</sup> | 6   |                         |                              |                                    |                                      |                                       |
|   |                          |                        |       |                   | Days >50 µg/m <sup>3</sup>                | 11    | Days              | 7   |                         |                              |                                    |                                      |                                       |
| <small>* See Footnote 4 in DMRB Volume 11 Chapter 3</small> |                          |                        |       |                   |   |       |                   |   |                         |                              |                                    |                                      |                                       |
|   |                          |                        |       |                   |   |       |                   | 8   |                         |                              |                                    |                                      |                                       |
|   |                          |                        |       |                   |   |       |                   | 9   |                         |                              |                                    |                                      |                                       |
|   |                          |                        |       |                   |   |       |                   | 10  |                         |                              |                                    |                                      |                                       |
|   |                          |                        |       |                   |   |       |                   | 11  |                         |                              |                                    |                                      |                                       |
|   |                          |                        |       |                   |   |       |                   | 12  |                         |                              |                                    |                                      |                                       |
|   |                          |                        |       |                   |   |       |                   | 13  |                         |                              |                                    |                                      |                                       |
|   |                          |                        |       |                   |   |       |                   | 14  |                         |                              |                                    |                                      |                                       |
|   |                          |                        |       |                   |   |       |                   | 15  |                         |                              |                                    |                                      |                                       |

Figure D4 Example Spreadsheet: Output from Local Assessment

D7.7 The regional assessment is very similar to the local assessment in appearance. Typical input and output sheets are illustrated in Figures D5 and D6 below:

| DMRB: Regional Impact Assessment |                 |                   |                  |                           |                             |                     |                          | INPUT SHEET            |             |                          |             |                   |             |
|----------------------------------|-----------------|-------------------|------------------|---------------------------|-----------------------------|---------------------|--------------------------|------------------------|-------------|--------------------------|-------------|-------------------|-------------|
| Step 1                           | Name            | Motorway widening |                  |                           |                             |                     |                          | (Step 4)               |             |                          |             |                   |             |
| Step 2                           | Year            | 2006              |                  |                           |                             |                     |                          | Step 5                 |             |                          |             |                   |             |
| Step 3                           | Number of links | 5                 |                  |                           | RUN COMPLETE                |                     |                          |                        |             |                          |             |                   |             |
| Step 4                           | Link number     | Link title        | Link length (km) | Traffic flow & speed      |                             | Road type (A,B,C,D) | Traffic composition      |                        |             |                          |             |                   |             |
|                                  |                 |                   |                  | AAADT (combined, veh/day) | Annual average speed (km/h) |                     | Vehicles <3.5t GVW (LDV) |                        |             | Vehicles >3.5t GVW (HDV) |             |                   |             |
|                                  |                 |                   |                  |                           |                             |                     | % passenger cars         | % light goods vehicles | Total % LDV | % buses and coaches      | % rigid HGV | % articulated HGV | Total % HDV |
|                                  | 1               | Motorway in 4-5   | 10.60            | 120,000                   | 112                         | A                   |                          |                        | 90          |                          |             |                   | 10          |
|                                  | 2               | Motorway in 5-6   | 8.20             | 110,000                   | 112                         | A                   |                          |                        | 89          |                          |             |                   | 11          |
|                                  | 3               | Argyll Road       | 3.20             | 30,000                    | 50                          | A                   |                          |                        | 93          |                          |             |                   | 7           |
|                                  | 4               | Barnwood Road     | 2.50             | 15,000                    | 40                          | B                   |                          |                        | 94          |                          |             |                   | 6           |
|                                  | 5               | Market Street     | 1.00             | 22,000                    | 35                          | D                   | 78                       | 15                     |             | 3                        | 4           | 0                 |             |
|                                  | 6               |                   |                  |                           |                             |                     |                          |                        |             |                          |             |                   |             |
|                                  | 7               |                   |                  |                           |                             |                     |                          |                        |             |                          |             |                   |             |

Figure D5 Example Spreadsheet: Input to Regional Assessment

| <i>DMRB: Regional Impact Assessment</i> |                       |                        |                  | <b>OUTPUT SHEET</b>          |                               |                    |
|---|-----------------------|------------------------|------------------|------------------------------|-------------------------------|--------------------|
| <b>Summary</b>                          |                       |                        |                  |                              |                               |                    |
| <b>Name</b>                             | Motorway widening     |                        |                  |                              |                               |                    |
| <b>Year</b>                             | 2006                  | <b>Number of links</b> | 5                |                              |                               |                    |
| <b>Pollutant</b>                        | <b>Total emission</b> | <b>Units</b>           |                  |                              |                               |                    |
| CO                                      | 918,599               | kg/year                |                  |                              |                               |                    |
| THC                                     | 117,954               | kg/year                |                  |                              |                               |                    |
| NO <sub>x</sub>                         | 1,127,396             | kg/year                |                  |                              |                               |                    |
| PM <sub>10</sub>                        | 40,475                | kg/year                |                  |                              |                               |                    |
| C                                       | 70,268                | tonnes/year            |                  |                              |                               |                    |
| <b>All links</b>                        |                       |                        |                  |                              |                               |                    |
| Link number                             | Link title            | Emissions              |                  |                              |                               |                    |
|   |                       | CO<br>(kg/year)        | THC<br>(kg/year) | NO <sub>x</sub><br>(kg/year) | PM <sub>10</sub><br>(kg/year) | C<br>(tonnes/year) |
| 1                                       | Motorway jn 4-5       | 500,597                | 62,717           | 618,445                      | 22,467                        | 38,708             |
| 2                                       | Motorway jn 5-6       | 356,128                | 46,254           | 463,412                      | 16,462                        | 28,121             |
| 3                                       | Argyll Road           | 35,899                 | 5,506            | 30,401                       | 1,003                         | 2,076              |
| 4                                       | Barnwood Road         | 15,996                 | 2,138            | 9,250                        | 321                           | 828                |
| 5                                       | Market Street         | 9,979                  | 1,339            | 5,888                        | 222                           | 536                |
| 6                                       |                       |                        |                  |                              |                               |                    |
| 7                                       |                       |                        |                  |                              |                               |                    |

Figure D6 Example Spreadsheet: Output from Regional Assessment



## ANNEX E DETAILED MODELLING

### E1 Introduction

E1.1 The DMRB Screening Method is intended to indicate whether or not detailed forecasts are necessary, by determining approximate concentrations in a simple and relatively straightforward way. If possible exceedences are identified, the conclusion reached is that a more detailed study is necessary.

E1.2 One major difference between the Screening Method given and a more detailed study is that the latter should take into account special and unusual features of the project. That is not the case in the screening procedure, which is based largely on average statistics (concerning, for example, the composition of the traffic and the site dispersion characteristics) and is universally applicable. It is specifically the unusual aspects of a project that determine the size and nature of those differences between the air quality impacts it forecasts and those determined in a more accurate assessment. It is not possible, therefore, to give specific or comprehensive guidance on how the more accurate assessment should be done. The methodology and data used, and the factors that are taken into account should be based on the properties of each individual project. The intention of this Annex is to draw attention to some features of road traffic pollution that can be of significance in the planning of an air quality impact assessment. The details of the assessment itself need to be given careful attention by a specialist in air quality, who is able to make the specific decisions needed in each individual case.

E1.3 There are two main elements in the prediction of air pollutant concentrations. It is necessary first to determine the sources of the pollutant(s) and the rates at which it is emitted, and secondly, to determine how it is dispersed and transformed in the atmosphere after its release.

### E2 Pollutant Emissions

E2.1 The emissions produced by road traffic vary significantly in space and time in response to a large number of factors. The accuracy with which emission estimates can be made depends on how many of those factors are taken into account and, importantly, on the extent and quality of available input information. A model that includes a large number of parameters can give a better representation of the processes leading to the emission of pollutants, but the potential for error and uncertainty in the model and its input data is increased.

E2.2 The most widely used approximations for estimating road traffic emissions are based on two parameters only: the type of vehicle and its average speed. In many cases, this is the only practical approach as data for a more complex evaluation are not available. However, in determining the methodology to use for a particular application, some attention should be given to the exact nature of the project and its likely consequences on vehicle emissions. In some cases, such as projects which result in variations in driving patterns but do not greatly affect average speed, a more detailed emission model may be required. It may be necessary to use an 'instantaneous' emission model, in which emissions are related to vehicle operation (usually via a vehicle speed-time profile) on a second-by-second basis. Examples of such models include MODEM<sup>33</sup> and PHEM<sup>34</sup>. These instantaneous emissions models usually require vehicle operating information from a micro-simulation traffic model such as VISSIM or PARAMICS.

E2.3 Table E1 presents a list of factors that are known to affect emissions from road vehicles, together with comments on the nature of their effects and on situations in which they might be important. Before a decision is made on a method for estimating emission rates, consideration should be given to whether any

<sup>33</sup> Jost P, Hassel D, Webber F-J and Sonnborn (1992). Emission and fuel consumption modelling based on continuous measurements. Deliverable No. 7, DRIVE Project V1053. TUV Rhineland, Cologne.

<sup>34</sup> Rexeis M, Hausberger S, Riemersma I, Tartakovsky L, Zvirin Y and Erwin C (2005). Heavy-duty vehicle emissions. Final Report of WP 400 in ARTEMIS (Assessment and Reliability of Transport Emission Models and Inventory Systems); DGTREN Contract 1999-RD.10429; University of Technology, Graz.

features of the project suggest that the use of basic, speed related emission factors is inappropriate. The judgement must be based on the practicality and likely increase in accuracy that might be derived from the inclusion of additional parameters. For example, the temperature of an engine has a large influence on emissions and the effects are reasonably well quantified, but it is rare that information on a project includes the engine temperature profile of the traffic. In many cases, the potential gain in accuracy through the use of engine temperature in the calculation of emission rates may be offset by the lack of realistic data on vehicle operating temperatures.

**E3 Other Sources of Emissions**

E3.1 It is likely in most cases that the most important source of emissions near to a project will be the traffic it carries. The resulting pollution concentrations will, however, be superimposed on the existing background and in some circumstances that can be an important contribution. In urban areas, background levels of pollution are often relatively high because of the many traffic and non-traffic sources found in towns and cities. In other areas there may be significant non-traffic sources of pollution such as power stations, industrial premises, mines and agriculture.

It is possible to treat contributions from other sources in two ways: their impact may be modelled, or based on

pollution measurements. The choice of approach will depend on the details of the project and on the availability of data – either as input for a model evaluation, or air quality data.

E3.2 A few general comments may, however, be made:

- The Department of the Environment, Food and Rural Affairs (Defra) operates a nationwide network of air quality monitoring stations. It may often be possible to obtain air quality data from a location with similar characteristics to that being studied.
- In addition to these permanent monitoring exercises, many ad hoc pollution surveys are carried out (for example by Local Authorities). They too may provide useful information.
- Where non-traffic sources of pollution are not expected to vary, a comparison between various project options can be carried out without reference to them. Relative impacts of the options will be properly evaluated even though forecast concentrations may be incorrect in absolute terms. Note that this is also true where a general change in background pollution is anticipated (owing, for example, to future reductions in vehicle emissions). Any widespread changes will take place independently of the project and will thus be applicable to all options.

**Table E1 Factors that Influence Vehicle Emission Rates**

| Factor              | Effects   |
|---------------------|---|
| <b>Vehicle type</b> | Emissions from different types of vehicle vary significantly. There is often a mismatch between vehicle classes used in traffic observation and modelling and those used in emissions studies. The basic vehicle properties that are distinguishable in terms of emissions are the engine type, the type of emission control system, the weight, the engine capacity and the emission standard to which the vehicle was certified. Often, some of these are approximated by a vehicle’s age, since that determines the level of technology to which it was built. The classes often used in traffic studies are based on more directly observable vehicle characteristics such as the body style (e.g. car, taxi, bus). Where there are no special features of a project that influence the traffic composition, it is often satisfactory to base emission factors on the composition of the UK vehicle fleet. There are many cases, though, where this will not be so: there are more buses and taxis than average in urban areas, lorries on motorways tend to have a higher average weight than those in towns, etc. Emission data for some types of vehicle are very limited, and it is sometimes necessary to equate them to vehicle types about which more is known. For example, London taxis may be considered equivalent to large diesel-engined cars, or buses to lorries of about the same gross weight. |

**Table E1 Factors that Influence Vehicle Emission Rates (continued)**

| Factor  | Effects  |
|---|--|
| <b>Fuel type</b>  | <p>The emission rates of petrol engined vehicles are quite different from those of diesels. In the future, it is possible that a wider range of fuels will be used for road transport. There is growing interest in gaseous fuels (e.g. CNG) and alternative liquid fuels (e.g. methanol), and they too exhibit different emission properties. In some cases, there is little doubt as to the type of fuel used by a certain type of vehicle (it can be assumed, for example, that all HGVs use diesel), but for some classes, such as cars and light vans, it is almost impossible to determine the precise split between fuel types. Unless there is a good reason to do otherwise, it is sufficient to base estimates on national statistics. It should be recognised that future events may alter the balance between fuels and forecasts of future emission rates may need to consider social, economic and political factors in addition to technological trends.</p>  |
| <p><b>Vehicle operation</b></p> <p>Speed</p> <p>Variation of speed</p> <p>Road geometry</p> <p>Engine temperature</p> | <p>Many operational features influence a vehicle's emissions. Some of the better known factors are:</p> <p>There is a well known correspondence between rates of emission and the average speed at which a vehicle is driven. It should normally be taken into account in an emission model.</p> <p>Emission rates tend to increase under variable operating conditions, compared with those during steady state driving. The effect is implicitly considered in most speed related emission factors since the variability of speed during a trip is closely related to the average speed. Slow speed journeys in towns involve frequent speed changes in response to the traffic conditions, while higher speed trips are normally driven more smoothly. Nevertheless, for two trips at the same average speed, emissions can vary substantially depending on speed variability. If a project has features that suggest speeds may vary more than average a more complex treatment may be warranted, though the availability of input data may be a limiting factor.</p> <p>The emissions from a vehicle negotiating a twisting road, or from a vehicle climbing a steep slope, will be increased because of the need to use lower gears and the extra load on the engine. Little is known quantitatively about these effects, and it may be that their influence on a vehicle's average speed makes implicit allowance for them in a basic, speed related emission model. Perhaps the largest of these effects is on the emissions from lorries climbing steep slopes (&gt;4% gradient) , so where roads have significant gradients and are expected to carry large numbers of HGVs, it may be necessary to make an allowance.</p> <p>Cold engines produce higher emissions than hot engines and emission control catalysts do not operate efficiently until they are warmed by the hot exhaust gases. Thus, where the number of vehicles starting from cold may be significant, the emission model should take this into account. Examples of where this could be important are locations near to car parks where engines may cool while vehicles are parked, or near to housing developments where the morning traffic may contain a large number of cars making their first journey of the day.</p> |

**Table E1 Factors that Influence Vehicle Emission Rates (continued)**

| Factor                       | Effects   |
|------------------------------|---|
| <b>Evaporative emissions</b> | Hydrocarbons are emitted by the evaporation of fuel as well as being emitted in a vehicle's exhaust. Because diesel is less volatile than petrol, it is usually only evaporative emissions derived from petrol that are considered. Emissions occur during the production and distribution of fuel and from vehicles in use. Vehicle evaporative emissions are of three main types: some vapour escapes from the fuel system when the vehicle is in operation and when it is parked with a warm engine, some is displaced from the fuel tank by liquid fuel when it is refilled, and some is emitted during the expansion of vapour in the fuel tank under the influence of ambient temperature variations. Quantitative data on evaporative emissions are very scarce, though some estimates suggest them to be a significant proportion of total hydrocarbon emissions. Their inclusion in an assessment should be considered if a project is likely to produce a change in local emissions. Such a case might be, for example, if a new petrol filling station is to be built. |

#### E4 Pollutant Dispersion

E4.1 In the same way that the emission of pollutants is influenced by local conditions, so is its dispersion in the atmosphere after release. This is normally simulated by using a standard dispersion model. Care should be exercised in the choice of an appropriate model and in the input data that are used. Advice is given on modelling in Defra's Technical Guidance LAQM TG(03).

E4.2 Many of the currently available dispersion models were developed some years ago. Some have been maintained and improved, but usually their basic principles remain unaltered. Thus, while there have been scientific advances in the understanding of atmospheric dispersion processes, and very major gains in the power of computers, allowing more complex models to be operated routinely using standard equipment, few applications have taken advantage of them. Considered in the overall context of air pollution forecasting, though, this limitation may not be as serious as it seems. It has already been noted that the use of a complex model only provides improved results if appropriately detailed and accurate input data are available, and in many cases that is not the case. There are uncertainties, imprecision and shortages of data for most of the stages of an air quality forecast.

E4.3 The models that are available are of several basic types. The simplest and most common are based on the Gaussian dispersion theory. This assumes that a pollutant emission develops into a plume, under the influence of the wind, and that the profile of

concentrations in the plume has a Gaussian distribution in the horizontal and vertical directions. The concentration at any point in the plume can be calculated from the standard deviation of the concentration distribution, which can be expressed in turn as a function of the downwind distance from source and a number of atmospheric parameters. Special adaptations are needed when this principle is applied to traffic pollution (it was developed on the basis of emissions from fixed point sources).

E4.4 Other models have been developed empirically, from the analysis of air quality data in relation to measured meteorological, traffic, site layout and other relevant variables. Given sufficient data for a thorough statistical analysis, these models can give accurate results. Important limitations are, however, that they apply strictly only to the location at which the measurements were made and that there is considerable uncertainty if the models are extrapolated beyond the range of the data on which they were based. They are, therefore, of limited use in making pollution forecasts for future years when vehicle emission characteristics will be very different.

E4.5 Two other types of model take as their basis the principle of conservation of mass of a pollutant as it spreads in the air. The Eulerian, or box, type of model calculates the change in concentration in a finite 'box' of air as the balance between material flowing into the box and that flowing out, with an allowance for any emissions occurring within the box. The second mass conservation type, the Lagrangian model, determines concentrations by following the movement of a 'parcel'

of polluted air under the influence of the wind. Both of these types of model can be developed to be considerably more complex than the Gaussian or empirical models and can, in theory at least, provide more accurate pollution estimates. The Gaussian model, for example, assumes that pollution is transported uniformly in the direction of the wind, while a Lagrangian model can simulate the effects of complex wind patterns.

E4.6 Allowances can be made in most of these models for concentration changes produced by chemical reactions in the air. This is of significance in this context mainly with regard to the oxides of nitrogen. It is again the case, though, that few fully developed models are available that provide an adequate treatment of chemical interactions. Most consider only the dispersion of inert gases.

E4.7 A choice of a specific dispersion model is largely dependent on the specific characteristics of the project under investigation. As in other cases, the decision must be based on the circumstances of the project and the practicality of obtaining satisfactory input data. For a rural project in uncomplicated surroundings, there is probably little to be gained from the use of complex modelling techniques, and standard Gaussian models are likely to be appropriate. Where the terrain is not simple, in a mountainous area or the centre of a town, for example, there may be some advantage from the use of other types of model and their application should be considered, always bearing in mind that the input data requirements will be considerably greater.

E4.8 Dispersion models of all classes need, in principle, common types of input data. They vary in the level of detail that is necessary. In addition to information on rates of emission, the essential requirements concern the site layout and meteorology. The physical layout of a project will normally be available from drawings made during its design process.

E4.9 Meteorological data can be obtained from the Meteorological Office's extensive network of meteorological monitoring stations. It is important that the data used be representative for the area, so they should be from the nearest possible location, and they should be taken from records covering a reasonable length of time (several years) in order that short term fluctuations are not given undue weight. Even so, there will inevitably be a measure of uncertainty as influences in the immediate locality of the project may be important. For example, wind data for London are available from measurements made at the London

Weather Centre, at a height of 70 m above the ground. Those measurements will be quite different from the conditions at ground level.

## ANNEX F ASSESSMENT OF DESIGNATED SITES

### F1 Background

F1.1 As well as impacts on human health, some air pollutants also have an effect on vegetation. Concentrations of pollutants in air and deposition of particles can damage vegetation directly or affect plant health and productivity. Deposition of pollutants to the ground and vegetation can alter the characteristics of the soil, affecting the pH and nitrogen availability that can then affect plant health, productivity and species composition. Increased greenhouse gas emissions on a global scale can affect the global climate, such that the ability of existing species to tolerate local conditions can change.

F1.2 The pollutant of most concern for sensitive vegetation near roads, and perhaps the best understood, is  $\text{NO}_x$ . The First EU Daughter Directive set a Limit Value for  $\text{NO}_x$  for the protection of vegetation (an annual mean of  $30 \mu\text{g}/\text{m}^3$ ) to be met by 2001. This value was based on the work of the UNECE and WHO, and has been incorporated into the UK Air Quality Limit Value Regulations 2001. The policy of the UK statutory nature conservation agencies<sup>35</sup> is to apply the  $30 \mu\text{g}/\text{m}^3$  criterion in internationally designated conservation sites and SSSIs on a precautionary basis<sup>36</sup>.

F1.3  $\text{NO}_x$  is composed of nitric oxide (NO) and its oxidation product nitrogen dioxide ( $\text{NO}_2$ ). The latter is taken up by plants principally through their stomata. Concentrations of  $\text{NO}_2$  are higher close to roads so vegetation in these areas is exposed to a larger source of nitrogen (N).

F1.4 Critical loads for the deposition of nitrogen, which represent the exposure below which there should be no significant harmful effects on sensitive elements of the ecosystem (according to current knowledge), have been established for certain habitats dependent on low nitrogen levels. Critical loads are expressed in deposition units of  $\text{kg N ha}^{-1} \text{ year}^{-1}$ .

F1.5 Deposition of particles, ammonia, metals and salt will also be increased close to the road. This could

affect vegetation in a number of ways:

- i) Dust or particles falling onto plants can physically smother the leaves affecting photosynthesis, respiration and transpiration. The literature suggests that the most sensitive species appear to be affected by dust deposition at levels above  $1000 \text{ mg}/\text{m}^2/\text{day}$ <sup>37</sup> which is five times greater than the level at which most dust deposition may start to cause a perceptible nuisance to humans. Most species appear to be unaffected until dust deposition rates are at levels considerably higher than this. Without mitigation, some construction activities can generate considerable levels of fugitive dust, although this is highly dependant on the nature of the ground and geology, time of year construction occurs in, length of time specific construction activity (e.g. boring) occurs for and prevailing meteorology during this activity.
- ii) An increase in the saltiness of roadside soils due to winter maintenance activities could lead to an accumulation of chloride ions in the plant.
- iii) Ammonia emissions from road vehicles (from petrol-driven vehicles fitted with catalytic converters and heavy duty vehicles fitted with selective catalytic reduction), although small in a national context, can lead to significant additional deposition of nitrogen to vegetation in immediate vicinity of roads (typically within 10 m).
- iv) Small quantities of heavy metals released during combustion and from vehicle wear and tear, may accumulate in soils near the road. However, such emissions cannot be reliably quantified or the negative ecological effects determined.

F1.6 Some of the pollutants emitted by vehicles will react over time to form secondary pollutants such as ozone and particles, which can also affect vegetation. Ozone is toxic to plants but concentrations tend to be

<sup>35</sup> Natural England, the Countryside Council for Wales, Scottish Natural Heritage.

<sup>36</sup> The Limit Value applies only to locations more than 20 km from towns with more than 250,000 inhabitants or more than 5 km from other built-up areas, industrial installations or motorways.

<sup>37</sup> Farmer A.M. The effects of dust on vegetation – a review. *Environmental Pollution*, 79, 63-75, 1993.

lower close to a road as it is scavenged by nitric oxide emitted by vehicles. As emissions of  $\text{NO}_x$  decrease in the future, ozone concentrations are expected to increase in urban areas and adjacent to roads and may pose an increased threat to vegetation in these areas. The reaction products of  $\text{NO}_x$ ,  $\text{SO}_2$  and  $\text{NH}_3$  (nitrate, sulphate and ammonium) have the potential to acidify the soil unless mineral weathering, chemical or microbial processes within the soil or liming can neutralise the acid. The nitrogen that is deposited in the UK is derived from oxides of nitrogen (oxidised nitrogen) and ammonia (reduced nitrogen) in roughly equal proportions (although the contribution of road transport is more in the form of  $\text{NO}_x$ ). Nitrogen is eventually deposited onto surfaces through wet and dry deposition. The components of nitrogen deposition are summarised by the equation:

$$N \text{ deposition} = \text{NO}_2 \text{ dry} + \text{NO}_2 \text{ wet} + \text{NH}_3 \text{ dry} + \text{NH}_x \text{ wet}$$

F1.7 The mean residence time in the atmosphere of reduced nitrogen is five hours, while that of oxidised nitrogen is approximately 30 hours; mean travel distances for reduced and oxidised nitrogen before it is deposited are 150 km and 1,000 km respectively. In the case of reduced nitrogen, which has a relatively short atmospheric lifetime, the effects of UK emissions occur largely within the UK, whereas 70% of oxidised nitrogen is exported from the UK. Similarly, some of the nitrogen deposited in the UK is produced by continental sources. Nitrogen deposition in terms of acidification and wet deposition is therefore a regional issue. The change in primary emissions as a result of a project are already assessed in the DMRB Screening Method, and so this guidance addresses only local impacts.

## F2 Assessment Procedure

F2.1 This assessment procedure was prepared in collaboration with the Joint Nature Conservation Committee and Natural England. The sites that should be considered for assessment are those for which the designated features are sensitive to air pollution, either directly or indirectly, and which could be adversely affected by the effect of local air pollution on vegetation within the following nature conservation sites SAC (SCI or cSAC), SPA, pSPA, SSSIs and Ramsar sites.

F2.2 Since little is known about the interactive effects of the different pollutants emitted from road transport the primary focus of the assessment is on reactive nitrogen compounds. However, impacts are likely to be as a result of the suite of emitted pollutants. Emissions of  $\text{NO}_x$  and  $\text{CO}_2$  are already calculated for their contribution to regional effects and global warming respectively, as part of the regional impact assessment, and so do not need to be considered further here.

F2.3 The simple assessment methodology in Chapter 3 of this guidance note describes how  $\text{NO}_x$  concentrations should be estimated. Therefore, the paragraphs below describe how to calculate nitrogen deposition within the Designated Site. The results of the assessment should be included in the intermediate assessment reports, the Environmental Statement, Appropriate Assessment if required, and be used in ecological impact assessments where appropriate.

### Method for Assessing Nitrogen Deposition

#### Step 1: Identify sensitive sites

Examine the Designated Sites to determine if any of these are sensitive to increases in nitrogen deposition. Sensitive sites include various types of woodland, heathland, grassland, bog and sand dune listed in Table F1. If there are no Designated Sites that are sensitive to nitrogen deposition, then there is no need to proceed any further with the nitrogen deposition assessment.

<sup>38</sup> <http://www.apis.ac.uk>

Step 2: Obtain total average N deposition for 5 km grid square

The average deposition rate from all sources of nitrogen (including the road of interest) should be obtained for the area of interest. Maps of total deposition rates can be found in the Air Pollution Information System (APIS)<sup>38</sup>. These are mapped on a 5 km x 5km basis so the area covered by each 5 km grid square should be noted. The data currently available on the system are for 1999-2001, which should be taken to be equivalent to those in 2000. The total average deposition rates obtained from the Air Pollution Information System for 2000 should be reduced by 2% per year to estimate deposition rates for the assessment years<sup>39</sup>.

Step 3: Obtain background NO<sub>2</sub> and NO<sub>x</sub> concentrations

These should be obtained from the Air Quality Archive. Concentrations in the assessment years should be estimated using the year adjustment calculator available from the website. The usual procedures should be followed when obtaining background rates for NO<sub>2</sub> predictions near a road, i.e. background concentrations should be obtained for 1 km squares up to 4 km away from the road so that the road contribution is not double counted. The average NO<sub>2</sub> concentration in the 5 km APIS square (i.e. average of the 25 one km grid squares) should also be calculated as this is included in the APIS deposition rate.

Step 4: Calculate NO<sub>2</sub> concentrations in a transect near the road

Calculate the annual mean NO<sub>2</sub> concentration in a transect up to 200 m away from each of the affected roads within or near the Designated Site. The calculations should be carried out for the opening year both with and without the project and the base year and should include the background concentration in the usual way. The DMRB Screening Method should be used to carry out the calculations unless the method is not appropriate for the scheme/project being assessed.

Step 5: Estimate dry deposition of NO<sub>2</sub> in a transect near the road:

The rate of nitrogen deposition due to dry deposition of NO<sub>2</sub> at each of the receptor sites should be estimated using the equation given below. The deposition rate in the 5 km x 5 km APIS square should also be calculated. Dry NO<sub>2</sub> deposition rates should be estimated using the following scaling factor which is based on a deposition velocity for NO<sub>2</sub> of 0.001 m/s (taken from EMEP Eulerian photochemistry model). 1 µg/m<sup>3</sup> of NO<sub>2</sub> = 0.1 kg N ha<sup>-1</sup> yr<sup>-1</sup>.

Step 6: Determine the road increment to NO<sub>2</sub> dry deposition

The dry NO<sub>2</sub> deposition rate for the APIS 5 km x 5 km square should be deducted from the receptor dry NO<sub>2</sub> deposition rate to give the increase in deposition rate at each receptor in the road corridor. This road increment should be added to the APIS average total deposition rate to give the total deposition rate at each receptor.

---

<sup>39</sup> Reduced nitrogen generally contributed about 45% of the total nitrogen deposited in Britain in 1997 with oxidised nitrogen contributing the remainder, although the proportion will vary depending on the location of the site and sources. Based on the results of transboundary deposition modelling for 1997 and 2010, deposition of reduced and oxidised nitrogen is expected to decrease on average across Britain by 1.5% and 2.6% per annum respectively due to increasingly stringent emission limits (National Expert Group on Transboundary Air Pollution on behalf of Defra and the devolved administrations. Transboundary Air Pollution: Acidification, eutrophication and ground level ozone in the UK. ISBN 1 870393 61 9, 2001). As the deposition of oxidised nitrogen is expected to decrease faster than that of reduced nitrogen, the proportion of the total nitrogen deposited from reduced nitrogen will increase in the future. It is expected to have reached 60% by 2010. If reduced and oxidised nitrogen are assumed to contribute to total deposition in equal proportions, then the annual decrease in nitrogen deposition can be assumed to be 2% (estimated in a non cumulative manner, i.e. decrease over five years is 5 x 2% = 10%) However, the deposition changes will not be linear across the country but 2% should be indicative of the typical change.



Step 7: Compare with critical loads.

The total deposition rate at each receptor should then be compared with the empirical critical loads for nitrogen set by the UNECE in 2003<sup>40</sup> that are shown in Table F1. Further information on critical loads for forest habitats is given in Table F2. Local factors such as phosphorus availability, site management (e.g. grazing) and rainfall will also affect the responsiveness of a site to altered nitrogen availability. Information on how these are likely to affect the critical load for selected ecosystems are given in the footnote to the Table. The Status of UK Critical Loads report<sup>41</sup> contains information on the applicability of the UNECE critical loads to sensitive UK habitats.

Step 8: Reporting

The change in deposition due to the project should be noted and discussed in relation to the critical load relevant to the interest features of the site, the background deposition and the extent of any exceedence. The results of this assessment should also be passed to an ecologist for inclusion in the ecological impact assessment (environmental impact assessment and/or Appropriate Assessment). The ecologist should consider the potential cumulative effects of all of the various impacts such as air pollution, water pollution and habitat loss and comment upon the effect of the project on the integrity of the Designated Site.

---

<sup>40</sup> UNECE. Empirical Critical Loads for Nitrogen - Expert Workshop, Berne 2002, Eds. Acherman and Bobbink. Environmental Documentation No. 164, SAEFL, 2003.

<sup>41</sup> UK National Focal Centre, CEH Monks Wood. Status of UK Critical Loads. Critical Loads Methods, Data and Maps. Available at [http://www.airquality.co.uk/archive/reports/cat11/maintext\\_7may.pdf](http://www.airquality.co.uk/archive/reports/cat11/maintext_7may.pdf)

**Table F1 UNECE Critical Loads for Nitrogen**

| Ecosystem type   | Critical load<br>(kg N ha <sup>-1</sup> y <sup>-1</sup> ) | Reliability | Indication of effects of exceedence   |
|--|---|-------------|---|
| <b>Forest habitats</b>   |   |             |   |
| Temperate and boreal forests   | 10-20   | #           | Changes in soil processes, ground vegetation, mycorrhiza, increased risk of nutrient imbalances and susceptibility to parasites |
| <b>Heathland, scrub and tundra habitats</b>                                      |   |             |   |
| Tundra   | 5-10 <sup>a</sup>   | #           | Changes in biomass, physiological effects, changes in species composition in moss layer, decrease in lichens                    |
| Arctic, alpine and subalpine scrub habitats                                      | 5-15 <sup>a</sup>   | (#)         | Decline in lichens, mosses and evergreen shrubs   |
| Northern wet heath<br>• 'U' <i>Calluna</i> dominated wet heath (upland moorland) | 10-20   | (#)         | Decreased heather dominance, decline in lichens and mosses  |
| • 'L' <i>Erica tetralix</i> dominated wet heath                                  | 10-25 <sup>a,b</sup>                                      | (#)         | Transition heather to grass   |
| Dry heaths   | 10-20 <sup>a,b</sup>                                      | ##          | Transition heather to grass, decline in lichens   |
| <b>Grassland and tall forb habitats</b>  |   |             |   |
| Sub-Atlantic semi-dry calcareous grassland                                       | 15-25   | ##          | Increase tall grasses, decline in diversity, increased mineralization, N leaching   |
| Non-Mediterranean dry acid and neutral closed grassland                          | 10-20   | #           | Increase in graminoids, decline typical species   |
| Inland dune pioneer grasslands   | 10-20   | (#)         | Decrease in lichens, increase biomass   |
| Inland dune siliceous grasslands   | 10-20   | (#)         | Decrease in lichens, increase biomass, increased succession   |
| Low and medium altitude hay meadows  | 20-30   | (#)         | Increase in tall grasses, decrease in diversity   |
| Mountain hay meadows   | 10-20   | (#)         | Increase in nitrophilous graminoids, changes in diversity   |
| Moist and wet oligotrophic grasslands<br>• <i>Molinia caerulea</i> meadows       | 15-25   | (#)         | Increase in tall graminoids, decreased diversity, decrease of bryophytes  |
| • Heath ( <i>Juncus</i> ) meadows and humid ( <i>Nardus stricta</i> ) swards     | 10-20   | #           | Increase in tall graminoids, decreased diversity, decrease of bryophytes  |
| Alpine and subalpine grasslands  | 10-15   | (#)         | Increase in nitrophilous graminoids, biodiversity change  |
| Moss and lichen-dominated mountain summits                                       | 5-10  | #           | Effects upon bryophytes or lichens  |
| <b>Mire, bog and fen habitats</b>  |   |             |   |
| Raised and blanket bogs  | 5-10 <sup>a,c</sup>                                       | ##          | Change in species composition, N saturation of <i>Sphagnum</i>  |
| Poor fens  | 10-20   | #           | Increase sedges and vascular plants, negative effects on peat mosses  |
| Rich fens  | 15-35   | (#)         | Increase tall graminoids, decrease diversity, decrease of characteristic mosses   |
| Mountain rich fens   | 15-25   | (#)         | Increase vascular plants, decrease bryophytes   |

**Table F1 UNECE Critical Loads for Nitrogen (continued)**

| Ecosystem type   | Critical load<br>(kg N ha <sup>-1</sup> y <sup>-1</sup> ) | Reliability | Indication of effects of exceedence   |
|--|---|-------------|---|
| <b>Inland and surface water habitats</b>                                 |   |             |   |
| Permanent oligotrophic waters<br>• Softwater lakes<br>• Dune slack pools | 5-10<br>10-20   | ##<br>(#)   | Isoetid species negatively affected<br>Increased biomass and rate of succession |
| <b>Coastal habitat</b>   |   |             |   |
| Shifting coastal dunes   | 10-20   | (#)         | Biomass increase, increase N leaching   |
| Coastal stable dune grassland  | 10-20   | #           | Increase tall grasses, decrease prostrate plants, increased N leaching          |
| Coastal dune heaths  | 10-20   | (#)         | Increased plant production, increase N leaching, accelerated succession         |
| Moist to wet dune slacks   | 10-25   | (#)         | Increased biomass, tall graminoids  |
| <b>Marine habitats</b>   |   |             |   |
| Pioneer and low-mid salt marshes   | 30-40   | (#)         | Increased late-successional species, increase productivity                      |

Reliability key: ## reliable, # quite reliable, (#) expert judgement

<sup>a</sup> Use towards high end of range at phosphorus limitation, and towards lower end if phosphorus is not limiting.

<sup>b</sup> Use towards high end of range when sod cutting has been practiced, use towards lower end of range with low intensity management.

<sup>c</sup> Use towards high end of range with high precipitation and towards low end of range with low precipitation.

**Table F2 Detailed Information on the UNECE Critical Loads for Forest Habitats**

| Forest habitats              | Critical load<br>(kg N ha <sup>-1</sup> y <sup>-1</sup> ) | Reliability | Indication of effects of exceedence  |
|------------------------------|---|-------------|--|
| <b>Soil processes</b>        |   |             |  |
| Deciduous and coniferous     | 10-15   | #           | Increased N mineralization, nitrification  |
| Coniferous forests           | 10-15   | ##          | Increased nitrate leaching   |
| Deciduous forests            | 10-15   | (#)         | Increased nitrate leaching   |
| <b>Trees</b>                 |   |             |  |
| Deciduous and coniferous     | 15-20   | #           | Changed N/macro nutrients ratios, decreased P, K, Mg and increased N concentrations in foliar tissue |
| Temperate forests            | 15-20   | (#)         | Increased susceptibility to pathogens and pests, change in fungistatic phenolics                     |
| <b>Mycorrhiza</b>            |   |             |  |
| Temperate and boreal forests | 10-20   | (#)         | Reduced sporocarp production, changed/reduced below-ground species composition                       |
| <b>Ground vegetation</b>     |   |             |  |
| Temperate and boreal forests | 10-15   | #           | Changed species composition, increase of nitrophilous species, increased susceptibility to parasites |
| <b>Lichens and algae</b>     |   |             |  |
| Temperate and boreal forests | 10-15   | (#)         | Increase of algae, decrease of lichens   |